

Thyro-P

Thyristor-Leistungssteller
kommunikationsfähig

Thyristor Power Controller
Communication Capable

DE EN



SAFETY INSTRUCTIONS

THE SAFETY INSTRUCTIONS AND OPERATING MANUAL ARE TO BE CAREFULLY READ PRIOR TO INSTALLATION AND COMMISSIONING.

OBLIGATION TO GIVE INSTRUCTIONS

The following safety and operating instructions must be carefully read before assembly, installation and commissioning of Thyro-P by those persons working with or on Thyro-P.

These operating instructions are part of the Power Controller Thyro-P.

The operator of this device is obliged to provide these operating instructions to all persons transporting, commissioning, maintaining or performing other work on the Thyro-P without any restrictions.

In accordance with the Product Liability Act, the manufacturer of a product has an obligation to provide explanations and warnings as regards:

- the use of the product other than for the intended use,
- the residual product risk and
- operating error and its consequences.

The information given below must be understood in this respect. It is to warn the product user and protect him and his systems.

PROPER USE

- The Thyristor Power Controller is a component which may only be used for control and regulation of electrical energy in industrial alternating current or 3-phase networks.
- The Thyristor Power Controller may at maximum be operated using the maximum admissible connected load according to information on the type plate.
- The Thyristor Power Controller may only be operated in connection with a suitable and series connected power supply disconnecting device.
- As a component the Thyristor Power Controller is unable to operate alone and must be projected for its intended use to minimize residual risks.
- The Thyristor Power Controller may only be operated in the sense of its intended use; otherwise, personal hazards (for instance electrical shock, burns) and hazards for systems (for instance overload) may be caused.

RESIDUAL HAZARDS OF THE PRODUCT

- Even in case of proper use, in case of fault, it is possible that control of currents, voltages and power is no longer performed in the load circuit by the Thyristor Power Controller.

In case of destruction of the power components (for instance breakdown or high resistance), the following situations are possible: power interruption, half-wave operation, continuous power flow. If such a situation occurs, then load voltages and currents are produced from the physical dimensions of the overall power circuit. It must be ensured by system design that no uncontrolled large currents, voltages or power results. It is not possible to totally exclude that during operation of Thyristor power controllers other loads show abnormal behaviour. The physically determined network reactions, depending on the operating mode, must be considered.

DANGER OF ELECTRIC SHOCKS

Even if the Thyristor Power Controller is not triggered, the load circuit is not disconnected from the mains.

It is possible to safely disconnect the Thyristor Power Controller as under IEC 60950

MALOPERATION AND THE RESULTS

With maloperation, it is possible that power, voltage or current levels which are higher than planned reach the Thyristor Power Controller or load. On principle, this can lead to the Power Controller or load being damaged. It is important that preset parameters are not adjusted in any way that may cause the Power Controller to overload.

TRANSPORT

Thyristor Power Controllers are only to be transported in their original packaging (protection against damage, e.g. due to impact, being knocked, soiling).

INSTALLATION

- If the Thyristor Power Controller is brought into the operations room from a cold environment, moisture can occur. Prior to it being commissioned, the Thyristor Power Controller must be absolutely dry. For this reason, wait for a minimum period of two hours before commissioning.
- Install the device upright.

CONNECTION

- Prior to connection, it must be ensured that the voltage information on the type plate corresponds with the mains voltage.
- The electrical connection is carried out at the designated points with the required cross section and the appropriate screw cross sections.

OPERATION

- The Thyristor Power Controller may only be connected to the mains voltage if it has been ensured that any hazard to people and system, especially in the load section, has been eliminated.
- Protect the device from dust and moisture.
- Do not block vents.

MAINTENANCE, SERVICE, MALFUNCTIONS

The icons used below are explained in the chapter safety regulations.



CAUTION

Should smoke, smell or fire occur the Power Controller must be disconnected from the mains immediately.



CAUTION

For maintenance and repair work, the Power Controller must be disconnected from all external voltage sources and protected against restarting. Make sure to wait minimum 1 minute after switch-off (discharge time of the attenuation capacitors). The voltage-free state is to be determined by means of suitable measuring instruments. This work is only to be carried out by a skilled electrician. The electrical regulations which are locally valid are to be adhered to.



CAUTION

The Thyristor Power Controller contains hazardous voltages. Repairs may generally only be performed by qualified and trained maintenance personnel.

**CAUTION**

Hazard of electrical shock. Even after disconnection from the mains voltage, capacitors may still contain a dangerously high power level.

**CAUTION**

Hazard of electrical shock. Even when the Thyristor Power Controller is not triggered, the load circuit is not disconnected from the mains.

**ATTENTION**

Different components in the power section are screwed in place using exact torques. For safety reasons, power components repairs must be performed by AEG Power Solutions GmbH.

TABLE OF CONTENTS

Safety instructions	2
Schedule of Illustrations and Tables	7
Safety Regulations	8
Remarks on the present operating instructions and Thyro-P	11
1. Introduction	13
1.1 General	13
1.2 Specific characteristics	13
1.3 Type designation	14
2. Functions	15
2.1 Overview of operating modes	15
2.2 Set point control characteristic	16
2.3 Control types	18
2.3.1 Controlled value	18
2.4 Indications	19
2.4.1 LED indications	19
2.4.2 Relay indications K1-K2-K3	19
2.5 Monitoring	20
2.5.1 Load monitoring	21
2.5.2 Ventilator monitoring	24
3. Mode of Operation	25
3.1 Local operating and display unit (LBA)	25
3.1.1 LBA keyboard functions	25
3.1.2 LBA main menu	26
3.1.3 LBA submenus	27
3.1.4 Copying function using the LBA	32
3.1.5 Operation display	32
3.1.6 Line diagram	33
3.1.7 Last function	33
3.1.8 Status line	33
3.1.9 LBA submenus with password protection	34
3.2 Cabinet installation kit (SEK)	34
3.3 Thyro-Tool Family	34
3.4 Diagnosis / fault indications	36
4. External Connections	38
4.1 Power supply for Thyro-P	38
4.2 Power supply for the control device A70	38
4.3 Power supply for the ventilator	38
4.4 RESET	39
4.4.1 Software-RESET	39
4.5 Controller lock	39
4.6 QUIT	40
4.7 Set point value inputs	40
4.8 ASM input	40
4.9 Analog outputs	40
4.10 Current transformer	41
4.11 Voltage transformer	41
4.12 Other connections and terminal strips	42
4.13 Synchronization	44
4.14 Component mounting diagram control device	45
5. Interfaces	46
5.1 RS 232 interface	47

5.2 Fibre optic interfaces	48
5.2.1 Fibre optic distribution system	48
5.3 Bus interfaces (option)	51
5.3.1 Profibus	51
5.3.2 Modbus RTU	55
5.3.3 DeviceNet	55
6. Mains Load Optimization	56
6.1 SYT-9 procedure	56
6.2 Software synchronization	56
6.3 ASM procedure (patented)	56
7. Connecting diagrams	58
7.1 1-phase	58
7.2 2-phase	59
7.3 3-phase	60
8. Special Remarks	61
8.1 Installation	61
8.2 Commissioning	61
8.3 Service	62
8.4 Checklist	62
9. Type Overview	64
9.1 Type range 400 volts	64
9.2 Type range 500 volts	65
9.3 Type range 690 volts	66
10. Specifications	67
11. Dimensional Drawings	70
12. Accessories and Options	83
13. Approvals and Conformities	84

SCHEDULE OF ILLUSTRATIONS AND TABLES

Fig. 1	Control characteristic for U control	17
Fig. 2	Total set point	17
Fig. 3	Switch-on fault bridging	20
Fig. 4	Absolute value monitoring	21
Fig. 5	Relative monitoring	21
Fig. 6	Local operating and display unit (LBA)	25
Fig. 7	Operation display	32
Fig. 8	Cabinet installation kit	34
Fig. 9	Example for the user interface Thyro-Tool Family	35
Fig. 10	File component mounting diagram control device	45
Fig. 11	Interfaces of Thyro-P	46
Fig. 12	Connection of a PC to Thyro-P via RS 232	47
Fig. 13	X10-allocation	48
Fig. 14	Signal converter RS 232/fibre optic	49
Fig. 15	Schematic diagram fibre optic Thyro-P with LLV and PC	50
Fig. 16	Profibus slot card	52
Fig. 17	Special function Motorpoti	53
Fig. 18	Special inputs	54
Fig. 19	Modbus slot card	55
Fig. 20	ASM wiring	57
Tab. 1	Behaviour in case of load change	19
Tab. 2	Partial load breakdown with heating elements switched in parallel, undercurrent	22
Tab. 3	Partial short-circuit with heating elements switched in series, overcurrent	23
Tab. 4	Overview monitoring	23
Tab. 5	Functions of the LBA-keys	26
Tab. 6	LBA main menu	27
Tab. 7	Copying function using the LBA	32
Tab. 8	Line diagram time base	33
Tab. 9	Elements of the status line	33
Tab. 10	Allocation of the message register	37
Tab. 11	Terminal strip X1	38
Tab. 12	RESET	39
Tab. 13	Controller lock	39
Tab. 14	QUIT	40
Tab. 15	Current transformer	41
Tab. 16	Voltage transformer	41
Tab. 17	Voltage measurement jumper	42
Tab. 18	Terminal strip X2 for K1, K2, K3	42
Tab. 19	Terminal strip X5	43
Tab. 20	Terminal strip X6	43
Tab. 21	Terminal strip X7	44
Tab. 22	Synchronization jumper	44
Tab. 23	Fibre optic distances	49
Tab. 24	Profibus baud rates	51
Tab. 25	Pin assignment X21	53

SAFETY REGULATIONS

IMPORTANT INSTRUCTIONS AND EXPLANATIONS

Operation and maintenance according to regulation as well as observance of the listed safety regulations is required for protection of the staff and to preserve readiness to operate. Personnel installing/uninstalling the devices, commissioning them, operating them, maintaining them must know and observe these safety regulations. All work may only be performed by specialist personnel trained for this purpose using the tools, devices, test instruments and consumables provided for this purpose and in good shape.

In the present operating instructions, important instructions are marked using the terms „CAUTION“, „ATTENTION“ and „REMARK“ as well as using the icons explained below.



CAUTION

This instruction shows work and operating procedures to be observed exactly to exclude hazards for persons.



ATTENTION

This instruction refers to work and operating procedures to be observed exactly to avoid damage or destruction of Thyro-P or parts thereof.



REMARK

This is where remarks about technical requirements and additional information is given, which the user has to observe.

ACCIDENT PREVENTION RULES

The accident prevention rules of the application country and the generally applicable safety regulations must be observed in any case.



CAUTION

Before starting any work on Thyro-P, the following safety regulations must be observed:

- switch voltage-free,
- secure against switching on,
- determine if it is voltage-free,
- ground and short-circuit it,
- cover or block neighboring parts under voltage.

QUALIFIED PERSONNEL

Thyro-P may only be transported, installed, connected, commissioned, maintained and operated by specialists in command of the respective applicable safety and installation regulations. All work must be monitored by the responsible specialist personnel. The specialist personnel must be authorized for the work required by the person responsible for the safety of the system.

Specialists are persons who

- have received training and have experience in the respective field of work,
- know the respective applicable standards, regulations, terms and accident prevention rules,
- have been familiarized with the function and operating conditions of Thyro-P,
- are able to detect and avoid hazards.

WORK OBSERVING SAFETY REGULATIONS

Before removing safety installations for performance of maintenance and repair work or other work, measures due to operation must be initiated.

Work observing safety regulations also means to point out faulty behaviour to colleagues and to notify the office or person responsible about defects detected.

INTENDED USE



CAUTION

The Thyristor Power Controller may only be employed in the sense of its purpose of use (see the section of the chapter safety instructions under the same name), otherwise hazards for persons (for instance electrical shock, burns) and systems (for instance overload) may occur.

Any unauthorized reconstruction and modification of Thyro-P, use of spare and exchange parts not approved by AEG Power Solutions as well as any other use of Thyro-P is not allowed. The person responsible for the system must ensure that

- hints on safety and operating instructions are available and observed,
- operation conditions and specifications are observed,
- protective installations are used,
- required maintenance work is performed,
- maintenance personnel are immediately notified or Thyro-P is immediately put out of commission if abnormal voltages or noises, higher temperatures, vibrations or similar occur to determine the causes.

These operating instructions contain all information required by specialists for use of Thyro-P.

Additional information and hints for unqualified persons and for use of Thyro-P outside of industrial installations are not contained in these operating instructions.

The warranty obligation of the manufacturer applies only if these operating instructions are observed.

LIABILITY

In case of use of Thyro-P for applications not provided for by the manufacturer, no liability is assumed. The responsibility for required measures to avoid hazards to persons and property is borne by the operator respectively the user. In case of complaints, please immediately notify us stating:

- type name,
- production number,
- objection,
- duration of use,
- ambient conditions,
- operating mode.

GUIDELINES

The devices of the type range Thyro-P conform to the currently applicable EN 50178 and EN 60146-1-1.

The CE mark on the device confirms observation of the general EG guidelines for 2006/95/EG – low voltage and for 2004/108/EG – electromagnetic compatibility, if the instructions on installation and commissioning described in the operating instructions are observed.

Regulations and definitions for qualified personnel are contained in DIN 57105/VDE 0105 Part 1.

Safe isolation to VDE 0160 (EN 50178 Chapter 3)

REMARKS ON THE PRESENT OPERATING INSTRUCTIONS AND THYRO-P

VALIDITY

These operating instructions refer to latest technical specification of Thyro-P at the time of publication and are for information purposes only. Every effort has been taken to ensure the accuracy of this specification, however, in order to maintain our technological lead and for product enhancement, we are continually improving our products which could, without notice, result in amendments or omissions to this specification. AEG PS cannot accept responsibility for damage, injury, loss or expenses resulting therefrom.

HANDLING

These operating instructions for Thyro-P are organized so that all work required for commissioning, maintenance and repair may be performed by corresponding specialist personnel.

If hazards to personnel and property cannot be excluded for certain work, then this work is marked using certain icons. The meaning of these icons may be found in the prior chapter safety regulations.

ABBREVIATIONS

In this description, the following specific abbreviations are used:

AEG PS	=	AEG Power Solutions GmbH
ASM	=	automatic synchronization in multiple Power Controller application (dynamic network load optimization)
DaLo	=	data logger (fault storage)
LBA	=	lokal operating and display unit
SEK	=	cabinet installation kit
LL	=	fibre optic
LLS	=	fibre optic transmitter
LLE	=	fibre optic receiver
LLV.V	=	fibre optic distribution supply
LLV.4	=	fibre optic distribution, 4-fold
SYT	=	synchronized clock
TAKT	=	Pulse full cycle

WARRANTY

Customer shall provide written particulars, enclosing the delivery note, within 8 working days to AEG PS on becoming aware of any defects in the goods during the Warranty period and shall use its best endeavours to provide AEG PS with all necessary access, facilities and information to enable AEG PS to ascertain or verify the nature and cause of the defect and carry out its warranty obligations.

If goods are found not to be defective or if any defect is attributable to Customer's design or material in operation of the goods, AEG PS will levy a testing charge and where relevant will return the goods to Customer at Customer's expense, and shall be entitled to payment in advance of the whole testing and transport charge before such return.

AEG PS accepts no liability for defects caused by the Customer's design or installation of the goods; or if the goods have been modified or repaired otherwise than as authorised in writing by AEG PS; or if the defect arises because of the fitting of the goods to unsuitable equipment.

AEG PS will cancel all possible obligations incurred by AEG PS and its dealers, such as warranty commitments, service agreements, etc., without prior notice if other than original AEG spare parts or spare parts purchased from AEG PS are used for maintenance or repair.

SERVICE HOTLINE

Our service is available to you through the following hotline:

AEG Power Solutions GmbH

Emil-Siepmann-Straße 32

D-59581 Warstein

Phone +49 (0) 2902 763-100

<http://www.aegps.com>

powercontroller@aegps.com

INTERNET

Further information on our company or our products can be found on the internet under

<http://www.aegps.com>.

COPYRIGHT

Passing on, duplication and/or takeover of these operating instructions using electronic or mechanical means, even in excerpts, is subject to express prior written approval of AEG PS.

© Copyright AEG Power Solutions 2012. All rights reserved.

Copyright notice

Thyro-P is an internationally registered trademark of AEG Power Solutions GmbH.

Windows and Windows NT are registered trademarks of Microsoft Corporation.

All other company and product names are (registered) trademarks of their respective owners.

1. INTRODUCTION

For transport, assembly, installation, commissioning, operation and decommissioning, the safety instructions contained in these operating instructions must be applied in any case and made available to all persons handling this product.



CAUTION

It is important that preset parameters are not adjusted in any way that may cause the Power Controller to overload. In case of uncertainties or missing information, please contact your supplier.

1.1 GENERAL

Thyro-P is a Thyristor Power Controller able to communicate. Below, it is also referred to simply as Power Controller. It may be employed in any place where voltage, current or power has to be controlled or regulated in processing technology. Several modes of operation and control, good coupling ability to process and automation technology, high control precision by application of a 32 bit RISC processor and simple handling ensure that Thyro-P is suitable for new applications as well.

Thyro-P is suitable for

- direct supply of ohmic loads
- for loads with large R_{hot}/R_{cold} ratio
- as primary Power Controller for a transformer with subsequent load

Due to use of state-of-the-art thyristors, the Thyristor Power Controller Thyro-P has a type range up to 2900A, the nominal design loads reach up to about 2860kW.

1.2 SPECIFIC CHARACTERISTICS

Thyro-P is characterized by a multitude of specific characteristics, for instance:

- easy handling
- menu-driven user interface
- type range 230-690 Volts, 37-2900A, single, double, triple phase
- broadband power supply AC 200-500V, 45-65Hz
- ohmic load and transformer load
- as well as load with large R_{hot}/R_{cold} for 1P and 3P
- soft start function for transformer load
- load circuit monitoring
- automatical rotating field recognition for 2P and 3P
- U, U^2 , I, I^2 , P control as well as without control
- operating modes TAKT, VAR, Soft-Start-Soft-Down, MOSI, ASM (optional sub-operating mode of TAKT)
- control of analog set points or via interfaces
- fibre optic and RS 232 interfaces as standard
- electrical separation according to EN 50178 chap. 3
- Measured values are given at analog outputs
- 4 set point channels incl. Motorpoti, which parameters can be set

The specific characteristics especially include the following options:

- Bus connection via bus adaptor cards to plug into the Thyro-P Power Controller, coupling to different bus systems, for instance Profibus, other bus systems upon enquiry.
- Patented ASM procedure for dynamic mains load optimization. The ASM procedure (automated synchronization of multiple Power Controller applications) is used for dynamic mains load optimization. It reacts to changes in load and set point, minimizes mains load peaks and associated mains feedback. Minimizing of mains load peaks means cost savings in operating and investment cost.

- Local operating and display unit (LBA), able for graphics display, menu-driven, pluggable. The integrated copying function by replugging the LBA enables simple transfer of Power Controller parameters between power controllers of the type Thyro-P.
- Cabinet installation kit (SEK) for the local operating and display unit. The SEK enables installation of the local operating and display unit into the switching cabinet door. It consists of cables and an installation frame.
- The PC-Software Thyro-Tool Familiy for effective commissioning and simple visualization tasks. Functions are for instance loading, storing, modification, comparing and printing of parameters, set points and actual value processing, line diagrams of process data (including printing and storing option), bar diagrams, simultaneous display of process data from different Power Controllers, simultaneous connection of up to 998 Thyro-P Power Controllers.

1.3 TYPE DESIGNATION

The type designation of the Thyristor Power Controllers are derived from the construction of its power section:

TYPE RANGE	DESIGNATION	FEATURES
Thyro-P	1P	single phase power section, for single phase operation
	2P	double phase power section, for three phase operation in three phase economizing circuits, not for phase-angle control (VAR)
	3P	three phase power section, for three phase operation
	.P400	Type voltage 230-400 Volt, 45-65 Hz
	.P500	Type voltage 500 Volt, 45-65 Hz
	.P690	Type voltage 690 Volt, 45-65 Hz
	.P ...-0037	Type current 37A (Typecurrent range 37A-2900 A)
-.... . H	Integrated semi-conductor fuse (all Thyro-P)
-.... . F	Forced air cooling with integrated ventilators
The complete type range can be found in the type overview in chapter 9.		

2. FUNCTIONS

For optimum adjustment to different products and production processes as well as differently electrical loads, the most favorable operating and control modes may be set according to the following overview.

2.1 OVERVIEW OF OPERATING MODES

This chapter gives an overview of the various, partly type-specific and optional operating modes.

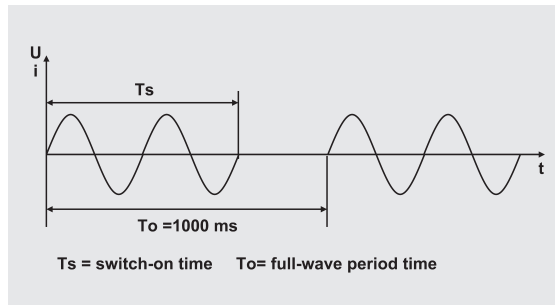

Full wave switch mode (TAKT)

Depending on the prescribed set point, the mains voltage is periodically switched. In this operating mode, almost no harmonics are created. Whole multiples of the mains periods are switched, avoiding DC components. The full oscillation clock principle is especially suited for loads with thermal inertia. For optimization of the mains load, the optional ASM process may be applied in this operating mode.

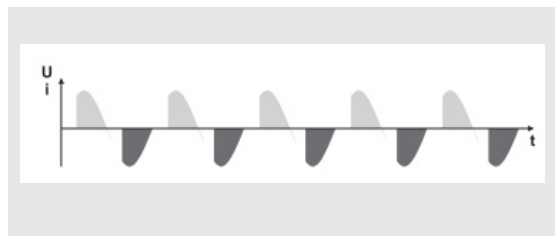

Phase-angle principle (VAR, with 1P and 3P)

Depending on the prescribed set point, the sine oscillation of the mains voltage is gated using a larger or smaller control angle α . This operating mode is characterized by high control dynamics. In case of phase-angle control, it is possible to compensate harmonics of the mains voltage by using circuit variants (for instance vector group transformer).

Soft-Start-Soft-Down (SSSD)

The operation of large individual loads using the operating mode TAKT may lead to voltage variations on the mains side. The operating mode SSSD greatly reduces the pulse-shaped mains load.

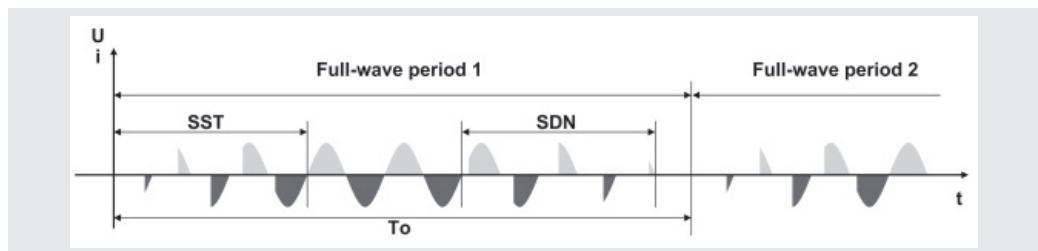

MOSI operation for 1P and 3P

MOSI is a sub-operating mode of the operating modes TAKT and VAR for sensitive heating materials with a high R_{hot}/R_{cold} ratio, for instance molybdenum disilicide. The Power Controller always starts with phase-angle maximum value and actual value to avoid high current amplitudes during the heating-up phase and then automatically switches to the set operating mode.

Mains load optimization (ASM procedure)

For systems in which several Power Controllers are employed in full wave switch mode TAKT, it is possible that individual Power Controllers are synchronized so that a regular mains load is achieved by defined switching of the individual Power Controller in sequence. This avoids load peaks by random simultaneous switching of many Power Controllers and load troughs are filled up. The upstream transformer and/or the upstream feed point may be designed for a lower load. Besides savings in investment and operating cost, lower mains reactions also result.

2.2 SET POINT CONTROL CHARACTERISTIC

The set point control characteristic of Thyro-P may be easily adapted for the control output signal of the upstream process controller or automation system. All signals customary on the market may be used. The adaption is made by changing the starting and ending points of the control characteristic. Inverted operation (ending value is smaller than the starting value in voltage or current) is also possible.

The effective set point is the total set point. It is formed by adding the four set points as shown in fig. 2.

In the simplest case all the set point values are added algebraically. The prerequisite for a set point to influence the total set point value is that it must be enabled by the set point Enable Register.

- Set point 1 (X5.2.10 - X5.1.13 ground) 0-20mA default
- Set point 2 (X5.2.11 - X5.1.13 ground) 0-5V default

The inputs set point 1, 2 are two electrically equal analogue inputs for current or voltage signals, with subsequent A/D converter (resolution 0.025% of the final value), and they may be set to the following signal ranges:

0(4)-20 mA	(Ri about 250Ω)	max. 24mA	siehe "ATTENTION"
0-5 V	(Ri about 8,8kΩ)	max. 12V	
0-10 V	(Ri about 5kΩ)	max. 12V	

The following table shall be used for the hardware configuration of the set point inputs (see also FILE COMPONENT MOUNTING DIAGRAM CONTROL DEVICE, figure 10). If the hardware configuration is changed, the Thyro-P parameters must be changed accordingly with the LBA or the Thyro-Tool.

X221 for Set point input 1

Bridge X221	Signal range	Set point input 1
closed*	0(4) -20mA	(X5.2.10)
open	0-5V / 0-10V	(X5.2.10)

X222 for Set point input 2

Bridge X222	Signal range	Set point input 2
closed	0(4)-20mA	(X5.2.11)
open*	0-5V / 0-10V	(X5.2.11)

* default



ATTENTION

If the open-circuit voltage of the connected set point exceeds 12V in the 20mA signal range, the set point inputs can be destroyed, if the belonging bridge (X221, X222) is open.

Within the stated input ranges, these values with the control characteristic may be adjusted to any common signal characteristic.

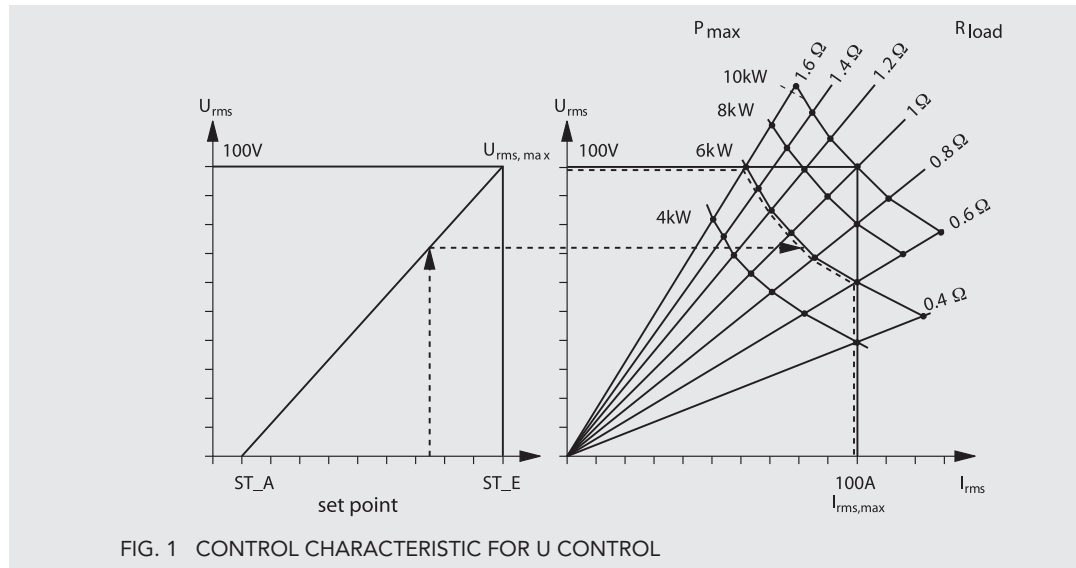

FIG. 1 CONTROL CHARACTERISTIC FOR U CONTROL

For a set point poti (e.g. 5-10 KΩ) 5V supply voltage can be taken from terminal X5.2.5 (Ri = 220Ω, short-circuit-proof).

SET POINT CONTROL CHARACTERISTICS

The set point control characteristic (Fig. 1) of Thyro-P may be easily adapted for the control output signal of the upstream process controller or automation system. All signals customary on the market may be used.

The adaption is made by changing the starting and ending points of the control characteristic. Inverted operation (ending value is smaller than the starting value in voltage or current) is also possible.

• **Set point 3:**

Set point of the superordinate system or PC via fibre optic connection (standard) X30, X31 or via the optional bus interface.

• **Set point 4:**

Set point input (motor potentiometer function) via LBA or RS 232 from the superordinate system or PC. Set point 4 is stored in case of mains failure.

EFFECTIVE TOTAL SET POINT VALUE

The algebraic addition of the results of set point (1,2) to set point 3 and 4 gives the (effective) total set point value for the set point control characteristic as shown in the following figure.

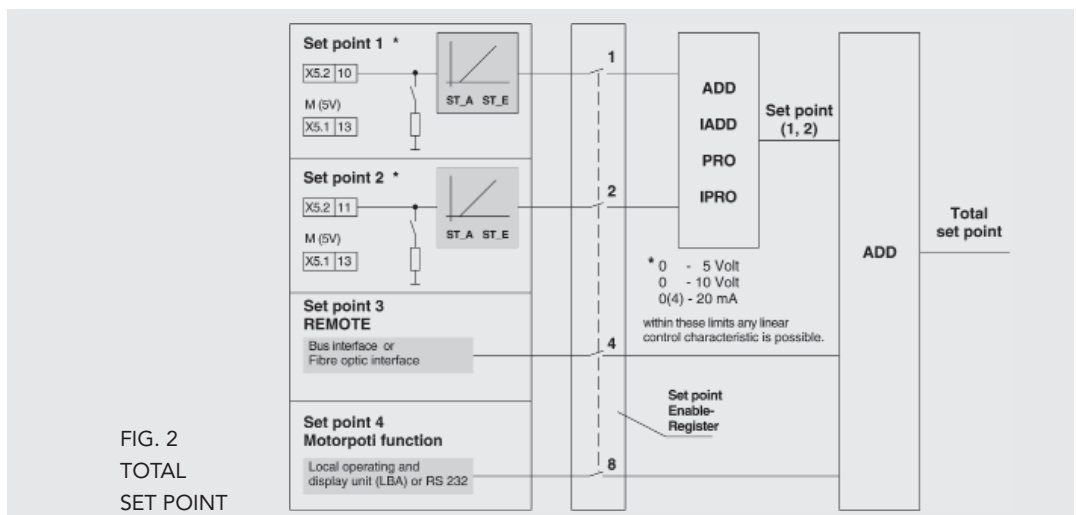

FIG. 2 TOTAL SET POINT

The prerequisite for a set point to influence the total set point value is that it must be enabled by the set point Enable Register. Set point 1 and 2 can be linked using the following functions. The result of this link is called set point (1,2).

Set point link

ADD Set point (1,2) = Set point 1 + Set point 2

IADD Set point (1,2) = Set point 1 - Set point 2

_Pro Set point (1,2) = Set point 1 * $\frac{\text{Set point 2 [\%]}}{100\%}$

_IPro Set point (1,2) = Set point 1 * $(1 - \frac{\text{Set point 2 [\%]}}{100\%})$

VALUE RANGE OF SET POINT (1,2)

For the link result of set point (1,2) the following value range applies:

$0 \leq \text{Set point (1,2)} \leq \text{Set point max} (U_{\text{max}}, I_{\text{max}}, P_{\text{max}})$.

SET POINT ENABLE REGISTER

The set point Enable Register (AD_P_SW_ENABLE, adr. 94) enables the 4 set points to be shut off or enabled independently. Only enabled set point inputs are part of the effective total set point value.

The shut off or inactive set points are shown by the LBA and can thus, if necessary, be checked before connecting.

The set point Enable Register can be changed from all service units (Bus, Thyro-Tool Family, LBA).

Example:

8	4	2	1	VALUE	ABBR.	EXPLANATION
1	1	1	1	15	STD	Standard (all ON)
1	0	0	0	8	LOC	Motor poti-set point 4 (LOCAL)
0	1	0	0	4	REMOTE	Bus set point 3
0	0	1	1	3	ANA	Analog-set points 1,2
0	0	0	0	0		All set points inactive

2.3 CONTROL TYPES

Thyro-P has five control types effective as underlying controls. Mains voltage variations and load changes are directly and therefore quickly adjusted by bypassing of the slow temperature control system.

Before commissioning of the Power Controller and selection of a control type, you should be familiar with the operating procedure respectively the effect for application.

2.3.1 CONTROLLED VALUE

The controlled value effective on the load is proportionate to the total set point, depending on the control type:

CONTROL TYPE	CONTROL VALUE (PROPORTIONATE TO THE TOTAL SET POINT)
P control	output (active) power, P
U control	output voltage, U_{rms}
U ² control	output voltage, U_{rms}^2
I control	output current, I_{rms}
I ² control	output current, I_{rms}^2

LIMITING OF SIGNALS

Independent of the control type set, additionally minimum and maximum limiting values may be set. For this purpose, also refer to Fig. 1 control characteristic.

The maximum limiting values determine the maximum modulation of the load.

The minimum limiting values should ensure minimum modulation via the control angle (for instance minimum heating of the load).

CONTROLLER RESPONSE

If the load resistance changes, for instance due to temperature effect, ageing or load fault, then the values effective on the load change as follows:

UNDERLYING		LOAD RESISTANCE DECREASES			LOAD RESISTANCE INCREASES			EFFECTIVE* LIMITATIONS	
CONTROL	LIMIT	P	U _{LOAD}	I _{LOAD}	P	U _{LOAD}	I _{LOAD}		
U	U _{rms max}	larger	=	larger	smaller	=	smaller	I _{rms max}	P _{max}
U ² (UxU)	U _{rms max}	larger	=	larger	smaller	=	smaller	I _{rms max}	P _{max}
I	I _{rms max}	smaller	smaller	=	larger	larger	=	U _{rms max}	P _{max}
I ² (IxI)	I _{rms max}	smaller	smaller	=	larger	larger	=	U _{rms max}	P _{max}
P	P _{max}	=	smaller	larger	=	larger	smaller	U _{rms max}	I _{rms max}
without control		larger	=	larger	smaller	=	smaller	U _{rms max}	I _{rms max}
								P _{max}	
* If one of the limits is exceeded, then the signaling relay K2 and the LED „limit“ react (default values of parameter settings).									
General modulation limit							T _s =T _{s max}		
							α=α _{max}		

TAB. 1 BEHAVIOUR IN CASE OF LOAD CHANGE

2.4 INDICATIONS

2.4.1 LED INDICATIONS

The LEDs on the front side signal the following states:

- ON green: operating indication, power supply controller board
red: RESET active
- CONTROL modulation percentage indication, flashing*
- LIMIT limitation is active, relay K2 switches*
- PULSE LOCK Controller Lock active, but load control is continued at pulse limits (default value = 0)*
- FAULT fault present*
- OVERHEAT overheating of power section (in case of ..HF types, check ventilator)*

* Default setting

Activation of the integrated semiconductor fuse may be signalled using the fault indicating relay K1 rest current, contactor, otherwise separate supply of the control device required). In case of Power Controllers from model current 495A, additional signalling is performed via an indicator at the semiconductor fuse.

2.4.2 RELAY INDICATIONS K1-K2-K3

The Thyro-P Power Controller is fitted with three relays. Each of these relays has a change over contact in principle be allocated a value in the event register. The following table shows the contactor allocation of the relays at the corresponding terminal strips. Presets of parameters by the works (default values) may be found in chapter 3.4.

ALARM RELAY K1

The relay K1 is activated if a fault is detected in the system. The effective direction, whether it should close or open in case of fault, may be set using the parameter K1 closed-circuit OFF, ON by using LBA or Thyro-Tool Family. Which indications lead to switching of the relay may also be set. Recommendation: keep the default setting.

LIMITING RELAY K2

The relay K2 only closes (in default setting) if at least one of the following values is exceeded:

- 1. max. admissible effective value of the load current
- 2. max. admissible effective value of the load voltage
- 3. max. admissible active power of the load

The relay releases if none of the values is exceeded anymore. It is possible to set which indications lead to switching of the relay. Recommendation: keep the default setting.

OPTIONAL RELAY K3

If changes are made to the default relay settings due to the application, then preferably the relay K3 should be reparameterized.

It is possible to realize functions like for instance a follow-up relay for ventilator control or by pass the alarm relay at startup of the system. It may also be used as a further alarm relay or limiting relay, by reparameterization.

The illustration shows the relay K3 for bridging the startup alarm.

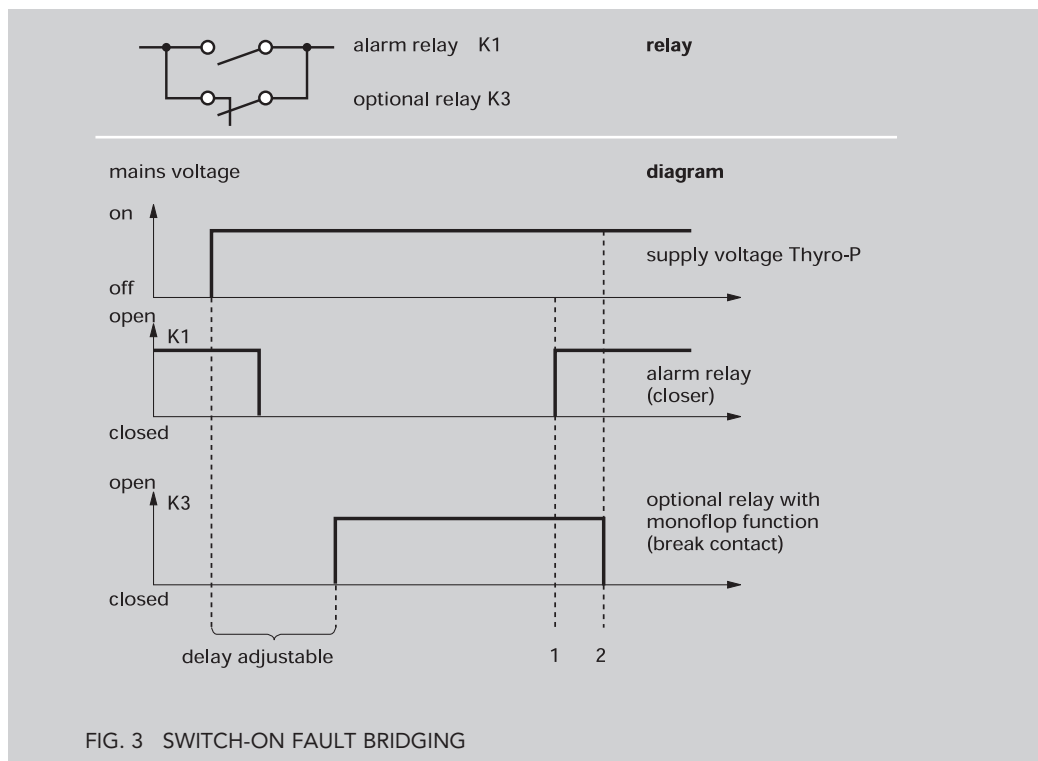

2.5 MONITORING

Faults occurring in the Power Controller or in the load circuit are signalled. Signalling is performed via LED (FAULT) and via relay with potential-free change-over contact. The fault buffer may be read via LBA or the interface after selecting the status line. Simultaneously with the fault signal, the pulse shutdown may optionally also be set (Imp.-Absch. OFF, ON). Faults having occurred are shown in the display of LBA by text status indications in the status line. After selecting the status line, the indication may be called up.

2.5.1 LOAD MONITORING

MONITORING OF THE LOAD AND MAINS VOLTAGE

Each power section is fitted with its own transformer for creating the synchronization voltages. This also allows monitoring of the phase voltages. In the LBA menu monitoring, the limits may be set for $U_{Line\ min}$ and $U_{Line\ max}$. If larger deviations are detected, then a fault indication is generated.

ABSOLUTE OR RELATIVE MONITORING

Relative monitoring for heating elements for $R_{hot}/R_{cold} \approx 1$ and absolute monitoring for heating elements with $R_{hot}/R_{cold} \neq 1$ are possible.

ABSOLUTE VALUE MONITORING CURRENT

This function allows monitoring of a freely selectable absolute current limit. The parameters for the value may be set in ampere.

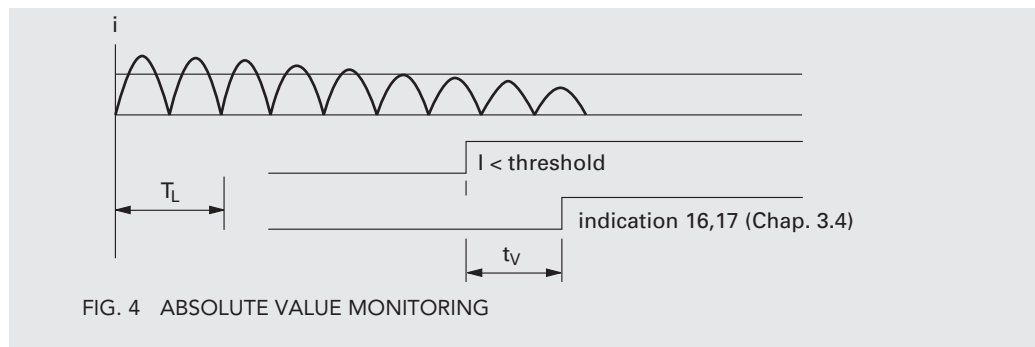

FIG. 4 ABSOLUTE VALUE MONITORING

This absolute value monitoring lends itself to one or more load resistances organized in parallel or in series. Generally, the effective current value measured is continuously compared with a presettable absolute current limit for undercurrent or overcurrent. If these limits are undercut or exceeded an indication shows. In case of resistor elements organized in parallel, it is therefore possible, using the lower current limit, to select a partial load interruption. Using the upper current limit, in case of resistors switched in series, short-circuiting of an element may be detected.

RELATIVE MONITORING

This monitoring is sensible if the resistance value of the load slowly changes. Changes in resistance may for instance be caused by temperature changes or by ageing. The current (b) of the Power Controller is regarded as 100% load current (current in fault-free state) after activation of the RESET or CONTROLLER LOCK. The RESET is automatically activated after each startup, restart or after mains outage. In case of relatively slow changes of the current, due to characteristics of the above mentioned heating elements, automatic adjustment of the internal reference value to 100% is performed (b').

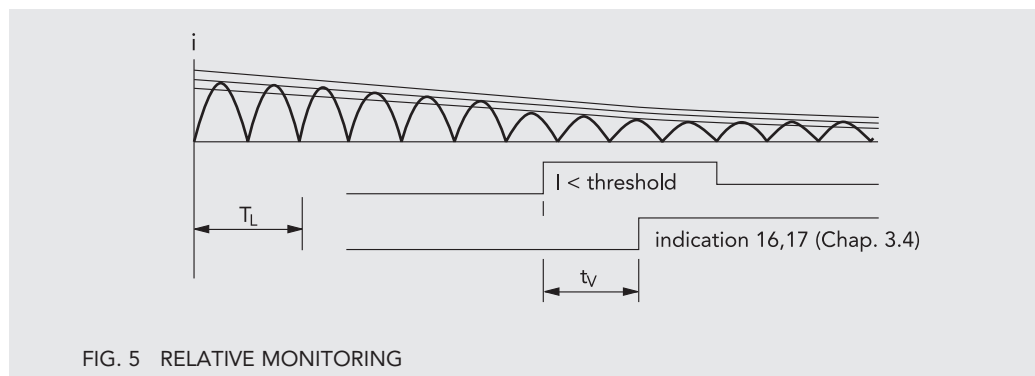

FIG. 5 RELATIVE MONITORING

Quick current changes, which may for instance occur in case of partial.

Quick current changes, which may for instance occur in case of partial short-circuit, may be detected by overcurrent monitoring (max., a – a').

Quick current changes, which may for instance occur in case of load breakdown may be detected by undercurrent monitoring (min., c – c').

NOTE FOR LOAD MONITORING:

Changes of the burden resistor and parameters can be necessary in case of small load currents or small current flow angles (i. e. small phase angles).

If a Thyro-P 3P is used in phase-angle operating mode, the star point of the load and the star point of the (built-in) voltage transformers should be connected together to ensure an accurate load monitoring. Please contact us in case of need..

The values in the following table apply to ohmic loads. Different values apply may be required for specific heating resistors, for instance IR radiators. The adjustable % values shown in the tables are load current variations on the present operating values.

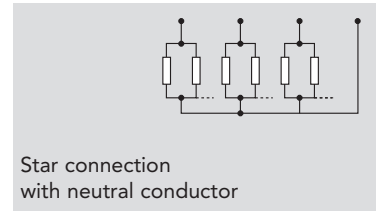
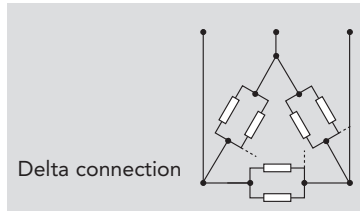
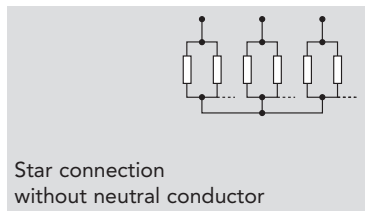
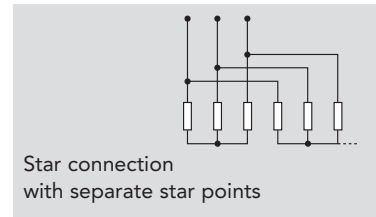

HEATING ELEMENTS IN PARALLEL FOR EACH STRAND	2P*/3P		3P		
	1P	STAR CONNECTION WITH SEPARATE STARPOINTS	STAR CONNECTION WITHOUT CONNECTED NEUTRAL CONDUCTOR	DELTA CONNECTION	STAR CONNECTION WITH CONNECTED NEUTRAL CONDUCTOR
5	10%	10%	–	–	10%
4	13%	13%	10%	–	13%
3	17%	17%	13%	10%	17%
2	25%	25%	20%	12%	25%
1	50%	50%	50%	21%	50%

* for Thyro-P 2P: additional external converters in phase L2 are possible.

TAB. 2 PARTIAL LOAD BREAKDOWN WITH HEATING ELEMENTS SWITCHED IN PARALLEL, UNDERCURRENT, RELATIVE MONITORING

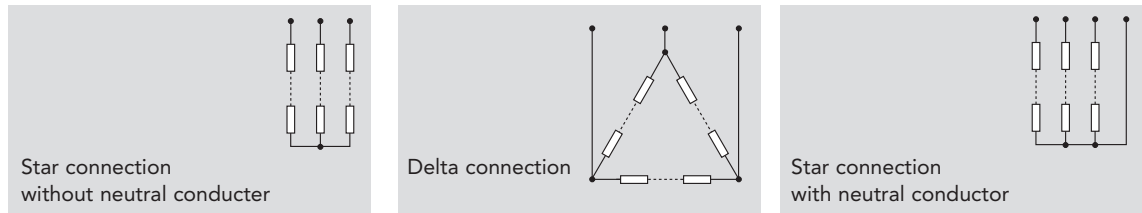

HEATING ELEMENTS IN SERIES FOR EACH STRAND	1P	STAR CONNECTION WITHOUT CONNECTED NEUTRAL CONDUCTOR	2P	DELTA CONNECTION	3P	STAR CONNECTION WITH CONNECTED NEUTRAL CONDUCTOR
6	10%	–	–	–	10%	10%
5	13%	10%	–	–	13%	13%
4	17%	10%	10%	10%	17%	17%
3	25%	14%	13%	13%	25%	25%
2	50%	25%	26%	26%	50%	50%

TAB. 3 PARTIAL SHORT-CIRCUIT WITH HEATING ELEMENTS SWITCHED IN SERIES, OVERCURRENT, RELATIVE MONITORING

AGEING OF LOAD RESISTORS

Thyro-P determines the load conductance separately for each phase. These values are available from LBA, Thyro-Tool Family and the Bus interface. The current resistance can be determined by reading out and converting from the conductance.

The following table offers an overview of the possible monitoring functions of the Thyristor Power Controller Thyro-P.

TYPE OF MONITORING		PARAMETER SETTINGS	DEFAULT / REMARKS
$U_{net\ max}$	mains overvoltage	input in volts	Type voltage + 20%
$U_{net\ min}$	mains undervoltage	input in volts	Type voltage - 20%
$I_{load\ max-REL}$	overcurrent overcurrent relative	0-100% Re: measured load current after each RESET/control lock	REL_ABS = REL UE_S = ON
$I_{load\ max-ABS}$	overcurrent absolute	input in ampere	REL_ABS = ABS UE_S = ON
$I_{load\ min-REL}$	undercurrent relative	0 to 99% Re: measured load current after each RESET/control lock	REL_ABS = REL UN_S = ON
$I_{load\ min-ABS}$	undercurrent absolute	input in ampere	REL_ABS = ABS UN_S = ON
pulse switch off by software	pulse switch off	ON: pulse switch off after fault indication OFF: in case of fault	indication is always issued in case of synchronization SYT 9, RESET of all Power Controllers is required
K1 open circuit	alarm relay K1	ON: relay K1 released in case of fault OFF: relay K1 pulled-in in case of fault	the alarm relay switches upon activation of RESET

TAB. 4 OVERVIEW MONITORING

2.5.2 VENTILATOR MONITORING

The separately ventilated Power Controllers (-...HF) are fitted with thermal monitoring. The temperature is measured on the heat sink. In case of a temperature overrange, a fault induction is issued (Profibus, LED OVERHEAT).



ATTENTION

Activating this monitoring function is obligatory if the Thyro-P is operated under UL conditions.

3. MODE OF OPERATION

This chapter shows the operating options of Thyro-P using LBA and Thyro-Tool Family.

3.1 LOCAL OPERATING AND DISPLAY UNIT (LBA)

The optional LBA (IP30, protection classification 3) has five keys and a backlit graphical LC display for 7 x 19 characters respectively 64 x 114 pixels. In the standard version, the languages German, English and French are available.

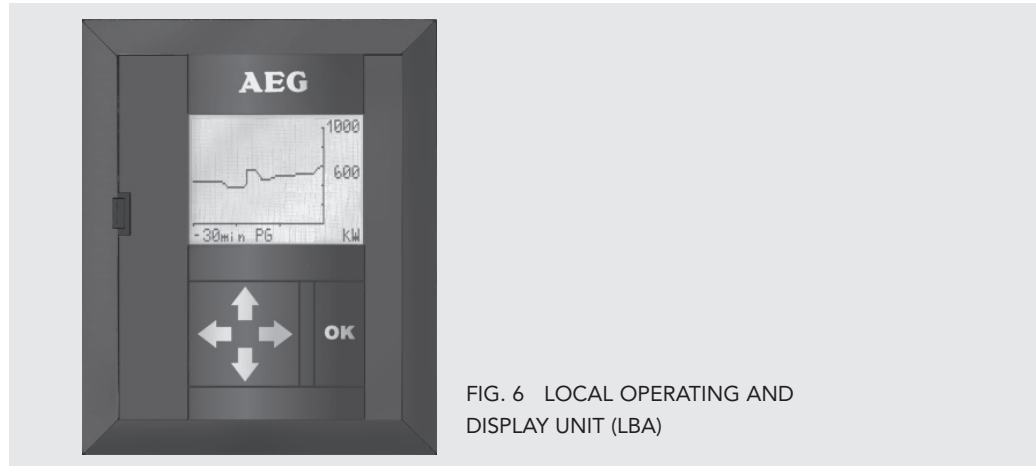

FIG. 6 LOCAL OPERATING AND DISPLAY UNIT (LBA)

The LBA may be connected or disconnected from the RS 232 interface of the Thyro-P control device during operation. After plugging into the interface and automatic loading of the parameters, the LBA displays its main menu.



ATTENTION

Before storing (store in Thyro-P / LBA under Thyro-P) the parameters must always be saved in the EEPROM of the LBA first (store in LBA).

If no key is pressed for one minute the operation display appears. This does not apply if a line diagram is running. If no communication is achieved after plugging in the LBA between LBA and Power Controller in case of fault, then a self-test is performed. Using the LBA, Thyro-P may be parameterized and monitored under menu control. It is possible to display up to three process data values (for instance the actual values of current, voltage or power occurring at the load) in double character height. Further values which may be displayed are the set point value as well as parameter data and fault indications. Furthermore, display of a value in graphical form as line diagram is possible. The time and value axes may be set by parameters and so adjusted to requirements. Using the LBA, the parameters of one Thyro-P may be copied to another Thyro-P. More details on this can be found in the chapter LBA menus.

3.1.1 LBA KEYBOARD FUNCTIONS

The LBA has a total of 5 standard keys: with an activatable parameterizing lock (see table 5). Four arrow keys and one OK key. By moving the cursor mark (>) using the corresponding keys (up arrow, down arrow), the desired function may then be selected using the OK key. An underlined language/function is in each case selected. An unnamed 6th key is available behind the opening in the front of the LBA, the reset key. If this is operated, then the functions RESET of Thyro-P is performed.

FUNCTIONS OF LBA KEYS:

KEY	DISPLAY	FUNCTION
←	Cursor before menu text:	selection of the higher level (back)
	Cursor on the figure:	select prior (higher value) position
→	Cursor on the figure:	select next (lower value) position
↑	Cursor before menu text:	move cursor to the prior line, possible scroll upward (only indented lines may be scrolled)
	Cursor on the figure:	increase value
	Cursor on the parameter:	switch on
↓	Cursor before menu text:	cursor on subsequent line, possible scroll downward
	Cursor on the figure:	reduce value until minimal admissible value is reached
	Cursor on the parameter:	switch off
OK	Cursor before menu text:	selection of a figure or of an input field
	Cursor on the figure:	takeover of the modification into Thyro-P and deselection of the selected field
	Cursor on the parameter:	takeover of the modification into Thyro-P and deselection of the selected field
	Operation display:	deselection of the operation display
	Parameter loading process Thyro-P → LBA	Parameterizing process is temporarily inactivated
OK OK	Line diagram:	deselection of the line diagram display
No key pressed (for 1 minute)		operation display is activated; this does not apply in case of selected line diagram
	Operation display:	Parameterizing lock is self-activating on release

TAB. 5 FUNCTIONS OF THE LBA-KEYS

3.1.2 LBA MAIN MENU

The top line always contains the name of the menu or of the submenu. The lowest line, the status line, always contains the configuration of the Power Controller or in case of existing indications, the word status indication.

The main menu (function selection menu) appears on the LBA display after plugging the LBA into Thyro-P. It looks like this:

MAIN MENU	FUNCTION
Language	selection operating language
Load/store data	load and store data
Set points/characteristics	set point processing
Parameter	display and modification of parameters
Operation display	select operation display
Last function	energy and operating hours

TAB. 6 LBA MAIN MENU

3.1.3 LBA SUBMENUS

The first six lines of the above main menu contain the names of the sub-menus. These are shown below, with explanations, in the sequence they are contained in the menu.

= Main menu (appears after plugging in the LBA)

Main menu	Submenu	Menu	next submenu	Default Value	User Value	Remarks
Sprache/language		Sprache/language Deutsch English Francais		x		
Open/save data		Open/save data Thyro-P -> LBA LBA -> Thyro-P Store in LBA Save Thyro-P	1 2			Loading, storing, copying of parameter sets Parameter from LBA-EEPROM to Thyro-P RAM Parameter from LBA-RAM to LBA-EEPROM Parameter from Thyro-P RAM to Thyro-P EEPROM
	1	Open data again Thyro-P -> LBA waiting time ASIC-SW Code LBA				Store parameters from Thyro-P in LBA Observe waiting time! OK key during charging releases the parameter lock Shows production date of controller software Shows version of LBA software
	2	Save data again LBA -> Thyro-P waiting time				Store parameters from LBA in Thyro-P Observe waiting time!
Set points/curve		Set points/curve motor pot. Term. (10) Term. (11) Master(bus) Act.pwr.tot:xx,xxmA Absolute set points STD, LOC, REMOTE, ANA ADD, IADD, PRO, IPRO 5V, 10V, mA term(10) 5V, 10V, mA term(11) Ctrl.start1 4.00mA Ctrl.end1 20.00mA Ctrl.start2 20.00V Ctrl.end2 10.00V		0		Remark: Display is refreshed after max. 10 sec. Display and modification set point 4 Display set point 1 Display set point 2 Display set point 3 (bus) Display total set point During active circuit set point is displayed in a submenu depending on control mode Choice of set point inputs SW1+SW2, SW1-SW2, SW1*SW2%/100%, SW1*(1-SW2%/100%) Selection signal type for set point 1* Selection signal type for set point 2* Control start set point SW1 Control start set point SW1 Control start set point SW2 Control end set point SW2 * refer to "ATTENTION" on page 16
Parameters		Adress Bus+LL-compound xxx		100		xxx for fibre optic 001 - 998 in case of Profibus DP 001 - 125 000 and 999 have specific functions

= Main menu (appears after plugging in the LBA)

Main menu	Submenu	Menu	next submenu	Default Value	User Value	Remarks
Parameters		Act. val. select				
		Analog outp.(32) Analog outp.(33) Analog outp.(34)	3			Parameterization for analog output 1, terminal 32 Parameterization for analog output 2, terminal 33 Parameterization for analog output 3, terminal 34
		Display top Display middle Display bottom	4			Parameterization for operation display, value top Parameterization for operation display, value middle Parameterization for operation display, value bottom
		Average xx Graphics	5	25		Mean value analog display of xx mains/cycle periods Parameterization line diagram
		3 Analog outp.(32) Analog outp.(33) Analog outp.(34)				
		Analog outp.(xx) Select and OK U1, I1, P1, PG U2, I2, P2 U3, I3, P3, alpha , , , set point $U_{min}, I_{min}, P_{min}$ $U_{max}, I_{max}, P_{max}$ Current output OFF,ON Full scale xx,xmA Offset Full scale value xxx y		U1(32) I1(33) P1(34)	0mA	Selected analog output 1,2,3 (terminal 32,33,34) Selection of (if existing in the Power Controller): U1, I1, P1, PG U2, I2, P2 U3, I3, P3, alpha, total set point Display total set point Minimum and maximum values of U, I, P since last RESET respectively voltage startup. Changeover 10V/20mA Measuring device end scale deflection e.g. 20mA Offset signal for output value, for instance 4mA Y=dimension depending on display V, A, kW
		4 Display top Display middle Display bottom				
		Display Select and OK U1, I1, P1, PG U2, I2, P2 U3, I3, P3, alpha , , , set point $U_{min}, I_{min}, P_{min}$ $U_{max}, I_{max}, P_{max}$				Operation display: top, middle, bottom (3 values) Selection of (if existing in the Power Controller): U1, I1, P1, PG U2, I2, P2 U3, I3, P3, alpha, total set point Display total set point Minimum and maximum values of U, I, P since last RESET respectively voltage startup.
		5 Line diagram				
		X - axis - time 1,5min;30min;1h;3h Y - axis - value U1, I1, P1, PG U2, I2, P2, alpha U3, I3, P3, set point Start graphic bar, average value		1.5min	U1	Scaling of the time axis (resolution pixels) Selection of (if existing in the Power Controller type): U1, I1, P1, PG (resolution 50 pixels) U2, I2, P2, alpha, U3, I3, P3, total set point, Start line diagram Display band (all measured values) or average value
	limitations					
	$U_{ens\ max}$ xxxxV $I_{ens\ max}$ xxxxA P _{max} xxxxkW op. time _{max} xxxxms Ft. _{Imp End} xxx°e Rr. _{Imp End} xxx°e on. time _{min} xxxxms $U_{ens\ min}$ xxxxV $I_{ens\ min}$ xxxxA P _{min} xxxxkW Phase swingL xxx			type type type 180 0 * * * * 0	Presets limiting values Display/default (at 3P default setting phase voltage) Display/default Display/default Only for the operating modes TAKT and SSSD (< T _o) Only for the operating mode VAR Only for VAR Phase swing for L1, L2, L3	

* password protection

 = Main menu (appears after plugging in the LBA)

Main menu	Submenu	Menu	next submenu	Default Value	User Value	Remarks
Parameters		Operating mode TAKT/FC VAR /PA SSSD/FC-PA Res No.ctrlld.phase 123 Load R,RL,transf.,C Service OFF,ON ASM OFF, ON, OFF MoSi OFF,R,S Afterpulse OFF,ON TDS OFF,ON Neutral OFF,ON		TAKT		Operating mode selection full oscillation clock principle Operating mode selection phase-angle principle Operating mode selection Soft-Start-Soft-Down Reserve Number of phases controlled (power paths) R: without startup ramps, C: like R, only for TAKT Operation without controls or limitations Display for ASM process Uses analog output 2, terminal 33 R: ramp, S: steer Only for 3-phase and VAR Only for 3-phase and VAR Only for 3-phase
		Hardware parameters Curr.conv. xxxxx Volt.conv. xxxx X501-3 1-2,2-3,3-4 Type current xxxxx Type voltage xxxx Burden load. xxx,xx Frequency Date yyyymmdd Time hhmmss Cntr. data log. x Peak value xxxxx SW_FA_1-6 list_L1-3_FA DAC1-3_FA TI_FA KP_FA Puls.s.off OFF,ON K1 closed-c OFF,ON		100 16 type type 1 Ohm 65000 * * * * * ON ON		Transformation ratio ü:1 Transformation ratio ü:1 Voltage adjustment measurement range 3 see chapter Voltage transformer See name plate See name plate current transformer adjustment incl. tolerances Only display of the mains frequency Input and display Input and display Current count of data logger counter 1 to 16 Peak current value at which instant impulse lock shall be set (in Ampere) IMAB: shutdown of the Power Controller in case of fault K1RU: switching open contact/closed contact (only K1)
		Monitoring Relative/Absolute Undercurrent OFF/ON Overcurrent OFF/ON Monit. L2 OFF/ON Monit. L3 OFF/ON U _{I100 max} xxxV U _{I100 max} xxxV Temperature Messages		R/A	x y	Display/setting of the monitoring values 1) absolute limiting value, see Fig. 4 1) absolute limiting value, see Fig. 4 1) change of absolute limiting value is only possible if the corresponding relative limiting value are zero/255. 2) change of absolute limiting value is only possible if the corresponding relative limiting value are zero/5000.
		Monitoring Relativ XR Undercurrent xx % YR Overcurrent xx % Value unequal ZERO!				
	Monitoring absolut XA Undercurrent xx A YA Overcurrent xxx A ZERO!					Cursor is in front of the selected value

* password protection

= Main menu (appears after plugging in the LBA)

Main menu	Submenu	Menu	next submenu	Default Value	User Value	Remarks																																																																																															
Parameters	6	<table border="1" style="width: 100%;"> <tr><td colspan="2">Temperature</td></tr> <tr><td>PT1000,PT100,NTC</td><td></td></tr> <tr><td>Ch.curve no. X</td><td></td></tr> <tr><td>Temperature xxx°C</td><td></td></tr> <tr><td>Lev.wire br.</td><td></td></tr> <tr><td>Lev. sh-circ.</td><td></td></tr> <tr><td>Comp.val.DAC</td><td></td></tr> </table>	Temperature		PT1000,PT100,NTC		Ch.curve no. X		Temperature xxx°C		Lev.wire br.		Lev. sh-circ.		Comp.val.DAC		* * *	PT1000 type		Sensor used Type-dependent, see chapter type overview Display actual temperature (relative value)																																																																																	
	Temperature																																																																																																				
	PT1000,PT100,NTC																																																																																																				
Ch.curve no. X																																																																																																					
Temperature xxx°C																																																																																																					
Lev.wire br.																																																																																																					
Lev. sh-circ.																																																																																																					
Comp.val.DAC																																																																																																					
7	<table border="1" style="width: 100%;"> <tr><td colspan="3">No.,DaLo,K1,K2,K3</td></tr> <tr><td>1</td><td></td><td></td></tr> <tr><td>2</td><td></td><td></td></tr> <tr><td>3</td><td></td><td></td></tr> <tr><td>4</td><td></td><td></td></tr> <tr><td>5</td><td></td><td></td></tr> <tr><td>6</td><td></td><td></td></tr> <tr><td>7</td><td></td><td></td></tr> <tr><td>8</td><td></td><td></td></tr> <tr><td>9</td><td></td><td></td></tr> <tr><td>10</td><td></td><td></td></tr> <tr><td>11</td><td></td><td>x</td></tr> <tr><td>12</td><td></td><td></td></tr> <tr><td>13</td><td></td><td></td></tr> <tr><td>14</td><td></td><td></td></tr> <tr><td>15</td><td></td><td></td></tr> <tr><td>16</td><td></td><td></td></tr> <tr><td>17</td><td></td><td></td></tr> <tr><td>18</td><td></td><td></td></tr> <tr><td>19</td><td>x</td><td></td></tr> <tr><td>20</td><td></td><td></td></tr> <tr><td>21</td><td></td><td></td></tr> <tr><td>22</td><td></td><td></td></tr> <tr><td>23</td><td></td><td></td></tr> <tr><td>24</td><td></td><td>x</td></tr> <tr><td>25</td><td></td><td></td></tr> <tr><td>26</td><td></td><td></td></tr> <tr><td>27</td><td></td><td></td></tr> <tr><td>28</td><td></td><td></td></tr> <tr><td>29</td><td></td><td></td></tr> <tr><td>30</td><td></td><td></td></tr> <tr><td>31</td><td></td><td></td></tr> </table>	No.,DaLo,K1,K2,K3			1			2			3			4			5			6			7			8			9			10			11		x	12			13			14			15			16			17			18			19	x		20			21			22			23			24		x	25			26			27			28			29			30			31			* * *			Status- / fault name Communication with RS 232 active Communication with fibre optic active Power value negative Communication fault RS 232 or fibre optic Synchr. interfaces failure (e.g. Profibus) External processor on the SSC signals fault K3 after RESET RESET active Data in EEPROM invalid (reload parameters) Internal message Limiting value is exceed Excess device temperature is present Instant current interruption has responded Internal message Fault exists in load circuit-collective fault 16,17 Undercurrent exists in the load circuit Overcurrent exists in the load circuit Internal message Circuit OK Undervoltage exists in the power section Overvoltage in the power section Internal message Internal message Synchronization fault Collective fault 4,6,9,10,11,12,14-24 (each fault leads to switching) Internal message Internal message Internal message Internal message Power Controller is in peak current limitation (only for operating mode MOSI) Temperature sensor, short circuit or sensor break
No.,DaLo,K1,K2,K3																																																																																																					
1																																																																																																					
2																																																																																																					
3																																																																																																					
4																																																																																																					
5																																																																																																					
6																																																																																																					
7																																																																																																					
8																																																																																																					
9																																																																																																					
10																																																																																																					
11		x																																																																																																			
12																																																																																																					
13																																																																																																					
14																																																																																																					
15																																																																																																					
16																																																																																																					
17																																																																																																					
18																																																																																																					
19	x																																																																																																				
20																																																																																																					
21																																																																																																					
22																																																																																																					
23																																																																																																					
24		x																																																																																																			
25																																																																																																					
26																																																																																																					
27																																																																																																					
28																																																																																																					
29																																																																																																					
30																																																																																																					
31																																																																																																					
		<table border="1" style="width: 100%;"> <tr><td colspan="2">Controls</td></tr> <tr><td>U_{load}^2</td><td>UxU</td></tr> <tr><td>$U_{load\ rms}$</td><td>U</td></tr> <tr><td>I_{load}^2</td><td>IxI</td></tr> <tr><td>$I_{load\ rms}$</td><td>I</td></tr> <tr><td>Active power</td><td>P</td></tr> <tr><td>No control</td><td></td></tr> <tr><td>PID factors</td><td></td></tr> </table>	Controls		U_{load}^2	UxU	$U_{load\ rms}$	U	I_{load}^2	IxI	$I_{load\ rms}$	I	Active power	P	No control		PID factors		8	UxU		Parameterization control characteristic Selection control characteristic U_{load}^2 Selection control characteristic $U_{load\ rms}$ Selection control characteristic I_{load}^2 Selection control characteristic $I_{load\ rms}$ Selection control characteristic effective load, P Selection set operation (phase-angle control angle) Parameterization controller parameters, password prot.																																																																															
Controls																																																																																																					
U_{load}^2	UxU																																																																																																				
$U_{load\ rms}$	U																																																																																																				
I_{load}^2	IxI																																																																																																				
$I_{load\ rms}$	I																																																																																																				
Active power	P																																																																																																				
No control																																																																																																					
PID factors																																																																																																					
	8	<table border="1" style="width: 100%;"> <tr><td colspan="2">PID factors</td></tr> <tr><td colspan="2">Sta.-Regl. OFF,ON</td></tr> <tr><td colspan="2"> </td></tr> <tr><td>P - part</td><td></td></tr> <tr><td>I - part</td><td></td></tr> <tr><td>D - part</td><td></td></tr> </table>	PID factors		Sta.-Regl. OFF,ON				P - part		I - part		D - part			ON		With standard control OFF the control parameters can be stipulated Controller parameters, P-part Controller parameters, I-part Controller parameters, D-part																																																																																			
PID factors																																																																																																					
Sta.-Regl. OFF,ON																																																																																																					
P - part																																																																																																					
I - part																																																																																																					
D - part																																																																																																					

* password protection

 = Main menu (appears after plugging in the LBA)

Main menu	Submenu	Menu	next submenu	Default Value	User Value	Remarks
Parameters		Times				
		Approach 1. xx°e		60°el		60°el. in case of 1P, otherwise 90°el., default value for transformers
		Softdown xx,xs		0.3		0 to (To-20ms), default value 400ms, ramp time up
		Softdown xx,xs		0.3		0 to (To-20ms), default value 400ms, ramp time down
		Cl.puls.dur xxxxxms		1.000		Display/Default of pulse period duration To
		On-time xxxxxms				Display of on-time Ts
		Sync.del. xxxms				Display of on-time Ts
		Min. pause		60ms		Transformer dependent, default value
		Puls.dur.max		50s		Fixed parameter control range, default value, password protection
		Set pointm2 OFF/ON	9		OFF	On activating, a jump is made from the operation display directly into this set point menu. The main menu can be reached from here with the left key.
	9	Local/Remote				Set point menu 2 direct from the operation display when parameter set point 2=ON
		Local/Remote				% , kW, A depending on set cascade control
		Motorp SW xx				
		Master SW xx				
		Total Pwr x				% , total power; U1, I1 depending on set cascade control
		Total SW x				Total set point value also in % , kW, V, A
		Pa-lock OFF,ON			OFF	With parameter lock ON, the lock, which is enabled with OK, is reactivated after one minute of operation display
		Password				
		Password entry				Enabling of password functions
		-----				Condition: Consultation/training
		***** o.k.				Valid until LBA is unplugged from the Power
		Controller				

		Code xxxxxxxxxx				EEPROM version number
Operation display		Operation display				Current operation indication, exit using OK
		U1 456,7V				Display top
		I1 1567,9A				Display middle
	P1 1234,8kW				Display bottom	
	Status messages	11				Display of status information: select this line and confirm using OK
	11	State messages				Examples for status indications
		jjjjmmtt ddmss				
		Limit				
		jjjjmmtt ddmss				
		Limit				
		jjjjmmtt ddmss				
		Undervoltage				
Last function		Last function				Return to the parameter last processed



REMARK

Type setting dependent on the type
 Some further menus are only accessible after input of a password.

3.1.4 COPYING FUNCTION USING THE LBA

It is possible to load the complete user-specific data record (parameters) of a Power Controller (for instance no. 1) into the memory of the LBA (RAM), store it in the LBA (EEPROM) and then copy it into another Power Controller (for instance no. 2):

PLUG LBA INTO POWER CONTROLLER NO. 1

1. reload data (data is stored in the LBA RAM)

2. storing in the LBA
(data is copied into the LBA-EEPROM)
After the waiting time unplug LBA from Power Controller 1.

Plug LBA into Power Controller no. 2

3. LBA -> Thyro-P
After the waiting time data from LBA are in Power Controller 2.

 4. Save Thyro-P
-

TAB. 7 COPYING FUNCTION USING THE LBA

Data from Power Controller 1 have now been copied to Power Controller 2.



ATTENTION

Only parameters of equal Power Controllers (for instance type voltage, type current, phase number) may be copied.

3.1.5 OPERATION DISPLAY

On the operation display, one, two or three actual values are optionally displayed in double digit size. An example for the operation display able to be configured using parameters is shown below:

U1	456.7V
I1	1567.9A
PG	1234.8kW
Status messages	

FIG. 7 OPERATION DISPLAY

The operating data displayed are the values U, I and P (P_{ges} for 3-phase system) of phase 1. It is also possible to display data of other phases. The lowest line is the status line; this is where the device configuration is displayed, if no indications are waiting. Otherwise, „status messages“ is displayed. By selecting the key, the indications are displayed:

Status messages	^v	fault type, load, Power Controller type, limitations, etc. are notified with the corresponding time of day. etc.
yyyymmdd	hhmmss	
limit	1250kW	
yyyymmdd	hhmmss	
undervoltage	<360V	

With the ← key it is possible to leave the status messages display. The operation display now appears without the word status message. Only when new information arrives does status message appear again in the bottom line of the operation display.

Additionally, input error indications or further parameters may be stated, which are self-explaining in connection with the menu heading.

As shown before, automatic switch to this display is made if more than one minute has passed since the last key has been pressed. The operation display is exited by simple acknowledgement (OK key).

3.1.6 LINE DIAGRAM

The line diagram has the same functionality as a page recorder. The „writing pen“ and therefore the current measurement value are found on the Y axis. The line diagram is scrolled left pixel by pixel. Measured value collection supplies one measured value each second. Because the time axis is resolved in 90 pixels, the following values result for the time bases from 1.5min up to 3h:

TIME BASE	MEASURED VALUES PER TIME-PIXEL
1.5 min	1 *
30 min	20
1 h	40
3 h	120

*) for this resolution, no band display is possible

TAB. 8 LINE DIAGRAM TIME BASE

There are two display modes: band and average value display. In case of band display, each measured value is displayed unfiltered. The number of measured values displayed for each time pixel is shown in the above table.

In case of average value display, the average value is formed from several measured values and displayed in one pixel.

The „windmill“ icon on the LBA display shows current data transfer between LBA and Power Controller. In case of still or non-existent icon, the data transfer is faulty.

To exit the line diagram, the OK key must be pressed twice.

3.1.7 LAST FUNCTION

If the OK key is pressed during operation display, then the LBA will display the main menu. If the lowest menu item last function is selected, then the menu is displayed which has been processed last before operation display.

3.1.8 STATUS LINE

The status line is the lowest line of each menu. It looks like this:

1P VAR Trafo UxU	Example for status line
------------------	-------------------------

and may contain the following values:

1P, 2P or 3P	for the Power Controller type
VAR, TAKT, SSSD	for the operating mode
Trafo, R-Last or RL-La.	for the load type
U, UxU, I, IxI or P	for the control type

TAB. 9 ELEMENTS OF THE STATUS LINE

3.1.9 LBA SUBMENUS WITH PASSWORD PROTECTION



REMARK

After password input, further parameters may be modified. These are mainly adjusting parameters required for achieving power control specifications. The modification of these parameters requires extended specialist knowledge (for instance by training) and is not required under normal circumstances.

3.2 CABINET INSTALLATION KIT (SEK)

Using the cabinet installation kit, the LBA may be installed in switching cabinet doors with a thickness of up to 4 mm. It consists of an adaptor frame 96x72mm (cut-out dimensions 92x68mm) and a cable. Using the cable, the LBA is connected to the RS 232 interface of Thyro-P.

The LBA locks in the adaptor frame and may only be removed with the cabinet door open. This enables an instructed specialist to set parameters (for instance adjustment to changing tools) and manual setting of set points (motor potentiometer) as well as for reading the actual value display without opening the cabinet door (VBG4). In order to avoid the accidental input of data by touching the LBA, there is a self-activating parameterizing lock to enable (see Table 5).



FIG. 8 CABINET
INSTALLATION KIT

If the LBA is connected to the Power Controller using a longer cable and does not operate, then this may possibly be remedied by increasing the supply voltage (open the jumper R 155 in the control device).



ATTENTION

In case of open jumper R 155, the LBA may not be connected to the Power Controller without cable (hazard of destruction). The position of the jumper on the control device PCB can be found in the component mounting diagram (Fig. 10, page 45).

3.3 THYRO-TOOL FAMILY

Thyro-Tool Family is an optional software for commissioning and visualization under Windows 95/98/NT 4.0/XP and higher. It includes all functions of Thyro-Tool P and it is connected to Thyro-P via either one of the two standard interfaces (RS 232 respectively fibre optic).

Thyro-Tool Family may be employed as an alternative to LBA and as already stated above has the following functions, for which several windows may be opened simultaneously:

- set point and actual value processing with overview display for 22 set point/actual value input options for Motorpoti and total set points.
- loading, storing, modification and printing of parameters
- comparison of parameters

It is possible to compare two sets of parameters (Power Controller or data file). It is thus possible, to detect deviations from the desired configuration.

- line diagrams of process data with printing function, as well as storage of faults (diverse measured values from different Thyristor Power Controllers may be displayed simultaneously).
- bar diagram display

It is possible to simultaneously display several bar diagrams. Each diagram has its own window.

These can be adjusted in size and location. The configuration of the display may be stored.

- simultaneous display of data and parameters from several Power Controllers
- simultaneous connection of up to 998 Thyro-P Power Controllers using fibre optic distributors
- settings of the interface (baud rate, com...)

Thyro-Tool Family is supplied with a help system and installed on the PC under user guidance using an installation software.

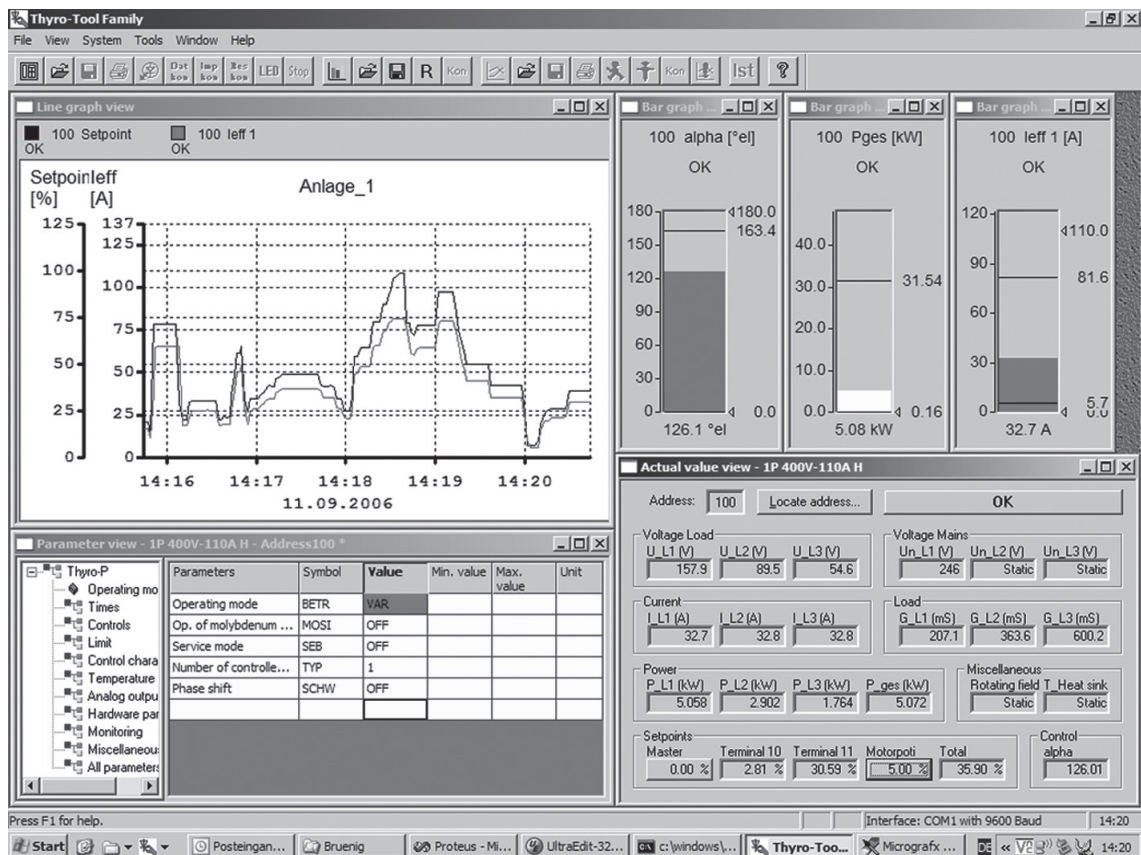

FIG. 9 EXAMPLE FOR THE USER INTERFACE THYRO-TOOL FAMILY

In the above illustration, you can see windows containing:

- 1 line diagram with several measured values
- 4 bar diagram (several are possible), as well as
- 1 parameter input section
- 1 actual value display

The location of the windows may be adjusted to the requirements by the user.

3.4 DIAGNOSIS / FAULT INDICATIONS

Faults can occur in the load circuit and in the Power Controller itself. Often, the sequence of fault indications or events is decisive for a positive diagnosis. Diagnosis of unexpected operating behaviour is performed by LEDs on the front panel of the control device, with parameter comparison (whereby the modified parameters may be listed), as well as by reading from the Thyro-P fault memory (data log). In Thyro-P, faults occurring and indications are entered in the fault memory with the event time and are preserved in case of mains outage as well. Up to 16 entries are possible. If further entries are made, then the first entry is overwritten. Therefore, the most current 16 events may be recalled at any time. Should faults or incidents occur, the selected operation display on the LBA will show status indications.

The indication is of the format

```
yyyymmdd hhmmss [ fault ] [ value ]
```

The status line only appears in the operation display (see fig. 7).

When using Thyro-Tool Family and an active line diagram, for any faults occurring their respective indications are displayed in a window and stored on disk associated with the line diagram.

Using an optional bus interface (e.g. Profibus DP), a corresponding indication is automatically issued.

The status indications (faults, warnings, messages) generated by Thyro-P may, as already mentioned, be classified as load and as Power Controller faults. Depending on the application, warnings or status messages may be read.

Data log

```
yyyymmdd hhmmss  
[ fault no. ] [ limiting value ]
```

All indications may be switched to the data log and the relays deviating from default settings.

EVENT NO.	PRESET LOG	RELAY	STATUS MESSAGE
1			Communication RS 232 interface active
2			Communication fibre optic interface active
3			Negative power (calculated value)
4			Communication fault RS 232 or fibre optic interface
5			Synchronous interface fault (for instance Profibus)
6			External processor on the SSC signals fault
7		K3	after RESET - monoflop function
8			Controller lock is active
9			Data in the EEPROM invalid (then reload Thyro-P parameter memory using Thyro-Tool Family)
10			Internal message
11		K2	Limiting exceeded
12			Device overtemperature
13			Quick circuit interruption has responded
14			Internal message
15			Failure in load circuit, collective failure
16			Undercurrent in load circuit, when activated
17			Overcurrent in load circuit, when activated
18			Internal message
19	DaLo		Indication appears on return of supply
20			Undervoltage in the power section
21			Overvoltage in the power section
22			Internal message
23			Internal message
24		K1	Synchronization fault
25			Collective fault (each fault leads to switching of the output)
26			Internal message
27			Internal message
28			Internal message
29			Internal message
30			For the operating mode MOSI: Power Controller has run into peak current limitation
31			Temperature sensor, short circuit or sensor break

TAB. 10 ALLOCATION OF THE MESSAGE REGISTER

4. EXTERNAL CONNECTIONS

This chapter describes external connections of the Thyro-P as well as all available terminal strips and signals as necessary. Shielded cables grounded on the Thyro-P side must be used for the connection of the control signals (setpoint inputs and analogue outputs). For the connections to RESET, Controller lock and QUIT, twisted cables must be used.

Bus interfaces can be found in chapter 5 INTERFACES. To operate the Thyro-P at least the following signals described up to chapter 4.5 QUIT must be connected.

4.1 POWER SUPPLY FOR THYRO-P

In the case of types 400V and 500V, connecting the regulator to the power supply also connects the control device Thyro-P to the power supply (see also chapter POWER SUPPLY FOR THE CONTROL DEVICE A70). The control device for 690V types must be supplied separately.

Details on connecting power supply can be taken from the chapters TECHNICAL DATA and connecting diagrams. This particularly applies when using the control device in UL applications.

4.2 POWER SUPPLY FOR THE CONTROL DEVICE A7

The Thyristor Power Controller Thyro-P is fitted with a wide-band power supply. The mains connection is designed for input voltages from 230V -20% to 500V +10% and nominal frequencies from 45Hz to 65Hz. The power consumption is max. 30W. Depending on the switch mode power supply, a 100VA control transformer must be used.

For the type ranges 400V (230-400V) and 500V nominal mains voltage, the control device is supplied directly from the power section. It is therefore a unit ready to connect.

STRIP TERMINAL X1

X1	mains supply connected internally
1	phase
2	N or phase

TAB. 11 STRIP TERMINAL X1



REMARK

If required, e.g. when operating with Profibus, the control device can also be supplied separately. With supply voltages outside the nominal range the control device must be supplied separately with an input voltage within the above-mentioned voltage range. The phase position of this control voltage is optional. In this case the plug (A70/X1) must be pulled.



CAUTION

The pulled plug has mains voltage of the load circuit! The new connecting lines must be fused according to the applicable regulations (plug see chapter 12).

4.3 POWER SUPPLY FOR THE VENTILATOR

With Thyro-P Thyristor Power Controllers furnished with integrated ventilators (HF types), the ventilator must be supplied with a voltage of 230V 50/60Hz according to the connecting plans and the dimensional drawings. The ventilator's power consumption is given in chapter 10, Technical Data.

**ATTENTION**

The ventilator must run when the Power Controller is switched on.

4.4 RESET

The input RESET (terminals X5.2.12-X5.1.14) is separated from the remaining system by an optoelectronic coupler. By opening the RESET jumper the Thyristor Power Controller is locked (load: 24V/20mA), i.e. the power sections are no longer triggered. On activating RESET, LED "ON" lights up red.

Functional procedure:

TERMINALS	FUNCTION
X5.12-14 closed	Enables the power sections, Power Contr. in operation
X5.12-14 open	Power Controller out of operation, communication via interfaces not possible
X5.12-14	system reinitialisation is closed

TAB. 12 RESET

The hardware RESET must be applied when synchronising the software of several Power Controllers (chapter 6.2 Software synchronisation). If the Power Controller is equipped with a Bus option, a Bus RESET also ensues from the hardware RESET. Apart from opening the jumper terminal X5.2.12-X5.1.14, the hardware RESET is also activated by supply voltage OFF or by reducing the supply voltage at the Power Controller (A70-X1) to below 160V.

4.4.1 SOFTWARE-RESET

The RESET function can be activated by signals via the status register (software RESET). The software RESET does not influence the Bus function.

4.5 CONTROLLER LOCK

The input controller lock (terminals X5.2.15 and X5.1.14) is electrically identical to the input RESET (electrical data as under 4.4.).

**ATTENTION**

When activating controller lock, the LED „PULSE LOCK“ is lit and the control device remains completely in operation. The total set point is therefore without effect, but the min. limiting values (TSMIN, HIME) remain active. This enables securing a certain quantity of electrical energy at the load.

TERMINALS	FUNCTION
X5.15-14 closed	Power Controller operating
X5.15-14 open	control pulses OFF (default value) or pulse limit

TAB. 13 CONTROLLER LOCK

All other functions of the Power Controller remain in operation. The state of the signalling relay does not change (parameter-dependent) and communications remains active. After closing the controller lock jumper, the controller is back in operation.

4.6 QUIT

The input acknowledge (Quit, X5.2.19) has a circuit identical with the input RESET. It must be short-circuited against ground (X5.1.14) so that any faults are acknowledged. The fault signalling relay is reset. The input must remain closed for at least 2 line periods to perform acknowledgement. After acknowledgement, the contactor must in turn be opened.

Function:

TERMINALS	FUNCTION
X5.19-14 open	controller operating
X5.19-14 closed*	faults are reset

* for at least 2 line periods

TAB. 14 QUIT

If the QUIT contact is reopened the Controller will reassume operation with its preset operating and control modes as well as its set point and limiting values.

4.7 SET POINT VALUE INPUTS

The set point inputs are described in chapter 2.2. Set point control characteristic.

4.8 ASM INPUT

This input (analog voltage signal) serves to measure the total current signal of the external apparent ohmic resistance. For further information refer to chapter "ASM procedure".

4.9 ANALOG OUTPUTS

The electrical values for current, voltage and power at the load as well as the set point are recorded by the Power Controller Thyro-P and may be optionally displayed using an external instrument or logged using a graph recorder.

For connection of external instruments, there are three actual value outputs (terminals X5.2.32, X5.2.33, X5.2.34, against X5.1.13). The selectable signal levels are 0-10 volts, 0-20mA, 4-20mA or - setting different parameters at a maximum compliance voltage of 10V. In case of active ASM procedure, only two of these three analog outputs are freely available (terminal X5.2.32, X5.2.34).

Each output has its own D/A converter. By setting parameters, it is possible to adjust the outputs to stored-program controls, measuring instruments, etc.

For instance, the following values may be output:

- currents, voltages or power of the individual phases, total power
- minimum or maximum values
- set points
- phase angles

The signals of the analog outputs are updated in each line (VAR) or TAKT period. Actual values always relate to the previous period. In operation mode VAR at a net period (e.g. 50Hz:20ms) and in operation mode TAKT at T0 (e.g. 1 sec.). Different factors (e.g. set point variations, load variations, limitings and the influence of operating modes with SSSD and MOSI) give the actual value signals dynamic rations which can be smoothed with a smoothing stage. The MEAN (VALUE) parameter is applied here. The following setting is recommended: MEAN(VALUE) = 25.

4.10 CURRENT TRANSFORMER



ATTENTION

By standard, each power section of the Power Controller has a current transformer. When using external current transformers, for instance on the secondary side of a transformer, these must be connected to the terminals X7.1 and X7.2 and terminated using a burden resistor! The burden resistor must be designed so that at nominal current a voltage drop of 1.0V_{rms} occurs at the burden resistance. For connection, take care to have the respective correct phase angle.

The internal current transformers may not be shunted, because the burden resistor R 40 is on the control cards. If load current monitoring of the phase 2 (not controlled) is desired for Thyro-P 2P, then an external current transformer and an external voltage transformer must be provided for this purpose.

CURRENT TRANSFORMER	TERMINAL X7.2	TERMINAL X7.1
phase L1	.11(k)	.12(l)
phase L2	.21(k)	.22(l)
phase L3	.31(k)	.32(l)

TAB. 15 CURRENT TRANSFORMER

The following parameters must be checked or adjusted:

HARDWARE PARAMETER

current transformer	xxxxx	UE_I
type current	xxxxx	I_TYP
burden resistance	xxx,xx	R_BUERDE_I

LIMITATIONS

Irms maxI1	xxxx	A IEMA
------------	------	--------



REMARK

Current measuring in not-controlled phases

Thyro-P 2P

Although phase 2 is not controlled in Thyro-P 2P, it is possible to take measuring values during this phase. A current transformer corresponding to T1 must be used and burdened (see type overview). It is connected as in table 23 to X7.1.22 – X7.2.21.

Thyro-P 1P

As only phase 1 is controlled with Thyro-P 1P, the measuring systems of phase 2 and 3 can be used freely. The corresponding current transformers (with max. 1V at nominal current) must be applied and burdened. Connection is carried out as in table 23 to terminal strips X7.1.22 – X7.2.21 for “phase 2”, and to X7.1.32 – X7.2.31 for “phase” 3.

The measuring values given do not influence the controller and are available for Bus interfaces, display and analog outputs. Parameter values must not be changed.

4.11 VOLTAGE TRANSFORMER

As standard, each power section is fitted with a voltage transformer for recording the load voltage. It is possible to measure voltages of up to 690V. The voltage transformers are wired to the control device A70 by the works.

LOAD VOLTAGE	TERMINAL X7.2	TERMINAL X7.1
phase L1	.15	.16
phase L2	.25	.26
phase L3	.35	.36

TAB. 16 VOLTAGE TRANSFORMER

In case of the Power Controller type 2P, the voltage transformers output the voltages L1-L2 and L3-L1. To achieve a good resolution of the voltage measurement, 3 measuring ranges are provided. Selection of the ranges is performed by means of 4-pin bars, which have been set to the Power Controller type voltage by the works. The pin bars are found on the control device A70 above the terminal X7.

MAINS VOLTAGE	SHORT CIRCUIT JUMPERS X501, X502, X503	MAX. MEASURING
230V	1 - 2	253V
400V	2 - 3	440V
500V respectively 690V	3 - 4	760V

TAB. 17 VOLTAGE MEASUREMENT JUMPER

If the jumpers are changed, then a change of parameters is required.

Hardware parameters

Type voltage	U_TYP
U eff max	UEMA
X501-3, 1-2, 2-3, 3-4	TYP-BEREICH
Mains voltage	U_NETZ_ANW (Thyro-Tool Family)



REMARK

Voltage readings in not-controlled phases

Thyro-P 2P

Although phase 2 is not controlled with Thyro-P 2P, it is possible to take measuring values during this phase. The voltage transformer suitable for standard rail assembly (order no. 2000000399) is to be used. Connection is made as in table 21 to X7.1.26 – X7.2.25. The maximum induced voltage of the transformer (incl. over-voltage) must be less than 50 volts.

Thyro-P 1P

As only phase 1 is controlled with Thyro-P 1P, the reading systems of phase 2 and 3 can be used freely. The voltage transformer suitable for rail assembly (order no. 2000000399) is to be used. Connection is made as in table 23 to terminals X7.1.26 – X7.2.25 for "phase 2" and X7.1.36 – X7.2.35 for "phase 3".

The measuring values do not influence the controller and are available for Bus interfaces, display and analog outputs. Parameter values must not be changed.

4.12 OTHER CONNECTIONS AND TERMINAL STRIPS

	ROOT*	BREAK CONTACT	CLOSER
Alarm relay K1	X2.7	X2.8	X2.9
Limiting K2	X2.10	X2.11	X2.12
Option K3	X2.13	X2.14	X2.15

* tie point

TAB. 18 TERMINAL STRIP X2 FOR K1, K2, K3

TERMINAL STRIP X5 IN THE CONTROL DEVICE

X5.1	FUNCTION	X5.2	FUNCTION
5	+5V	5	+5V
13	ground 5V	10	set point 1
13	ground 5V	11	set point 2
13	ground 5V	32	analog output 1
13	ground 5V	33	analog output 2
13	ground 5V	34	analog output 3
13	ground 5V	16	ASM input
21	-15V	17	GSE connection
14	ground 24V	12	RESET
14	ground 24V	15	controller lock
14	ground 24V	18	SYT9 connection
14	ground 24V	19	QUIT
20	+24V*	20	+24V*

* Loading: $I_{X5.1,20} + I_{X5.2,20} + I_{X21,9} \leq \text{max. } 80\text{mA}$

TAB. 19 TERMINAL STRIP X5

Terminal strip X6 in the control device

At the terminal strip X6, wiring between the control device A70 and the control cards A1, A3 and A5 of the power section is performed by the works. Allocation of the terminal strip is as follows:

X6	Name
11	thyristor L1 neg.
12	+5V
13	thyristor L1 pos.
21	thyristor L2 neg.
22	+5V
23	thyristor L2 pos.
31	thyristor L3 neg.
32	+5V
33	thyristor L3 pos.
41	input temperature sensor
42	ground temperature sensor

TAB. 20 TERMINAL STRIP X6

Each thyristor is controlled by 20mA current supply switching to ground.

The ventilator monitor is connected to the terminals X6.41 and X6.42 in separately ventilated devices (..HF). The temperature of the power section is monitored using a PT 1000 temperature sensor. In case of overheating of the power section, for instance caused by outage of the ventilator, a fault indication is generated and the alarm relay is activated (default values). The temperature may be enquired by the interfaces.

4.13 SYNCHRONIZATION

By standard, each power section is fitted with a transformer for an input voltage of up to 690V. After filtering, the synchronization signal for control of the thyristors is generated from the secondary voltage. The connections are wired by the works. This includes the following terminals:

TERMINAL STRIP X7

X7.1	X7.2	NAME
12	11	current transformer phase L1
14	13	sync phase L1
16	15	load voltage phase L1
22	21	current transformer phase L2
24	23	sync phase L2
26	25	load voltage phase L2
32	31	current transformer phase L3
34	33	sync phase L3
36	35	load voltage phase L3

TAB. 21 TERMINAL STRIP X7

For the synchronization the following jumpers are necessary on the componentry of the control device.

THYRO-P	SHORT CIRCUIT JUMPER	
1P	X507	X508
2P	X507	-
3P	-	-

TAB. 22 SYNCHRONIZATION JUMPER

4.14 COMPONENT MOUNTING DIAGRAM CONTROL DEVICE

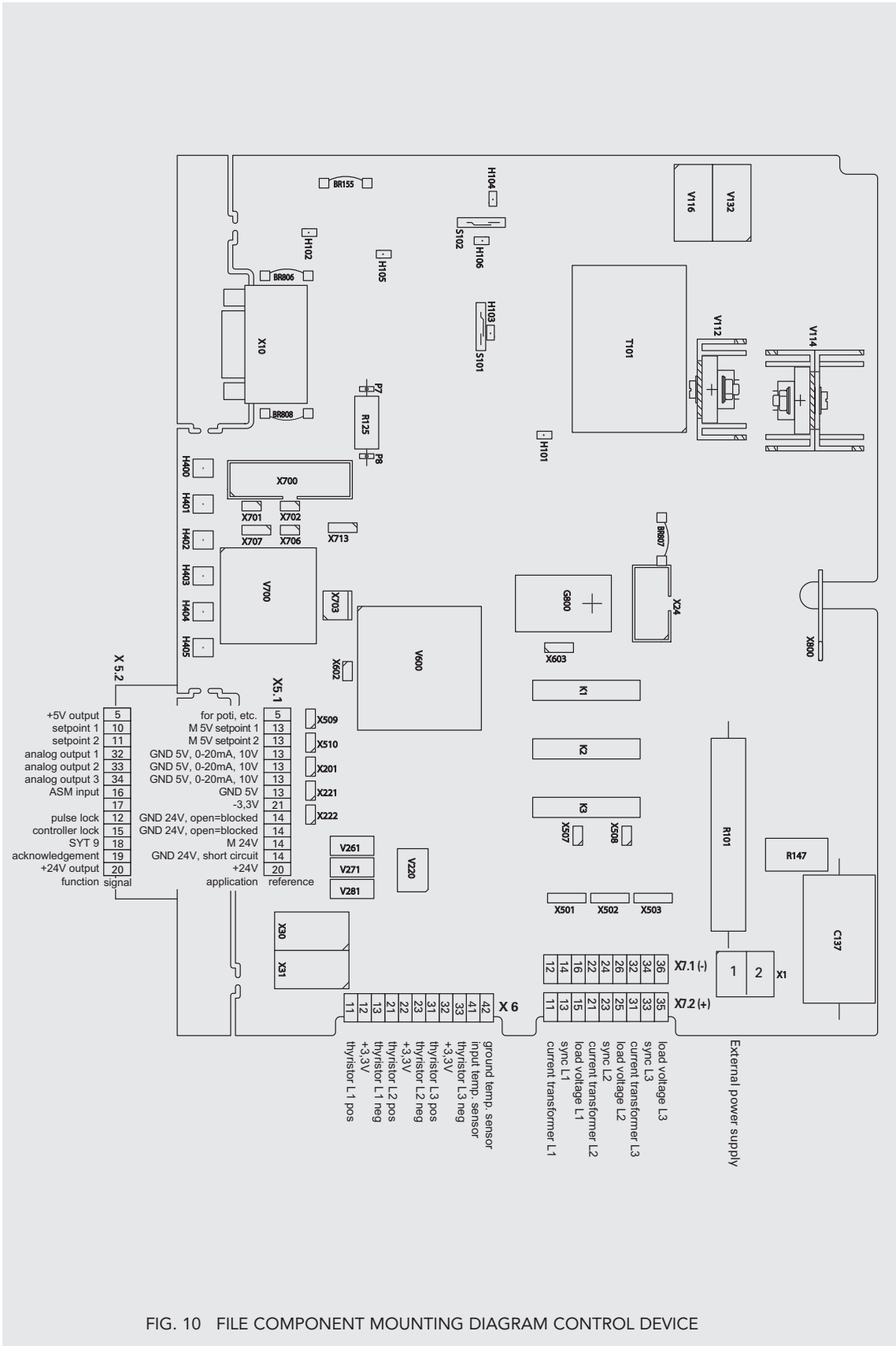

FIG. 10 FILE COMPONENT MOUNTING DIAGRAM CONTROL DEVICE

5. INTERFACES

Necessary process optimization as well as the requirements made of high, continuous and documentable quality in production processes often require the use of digital process communications. It allows interlinking of many signals and enables their evaluation in an efficient manner.

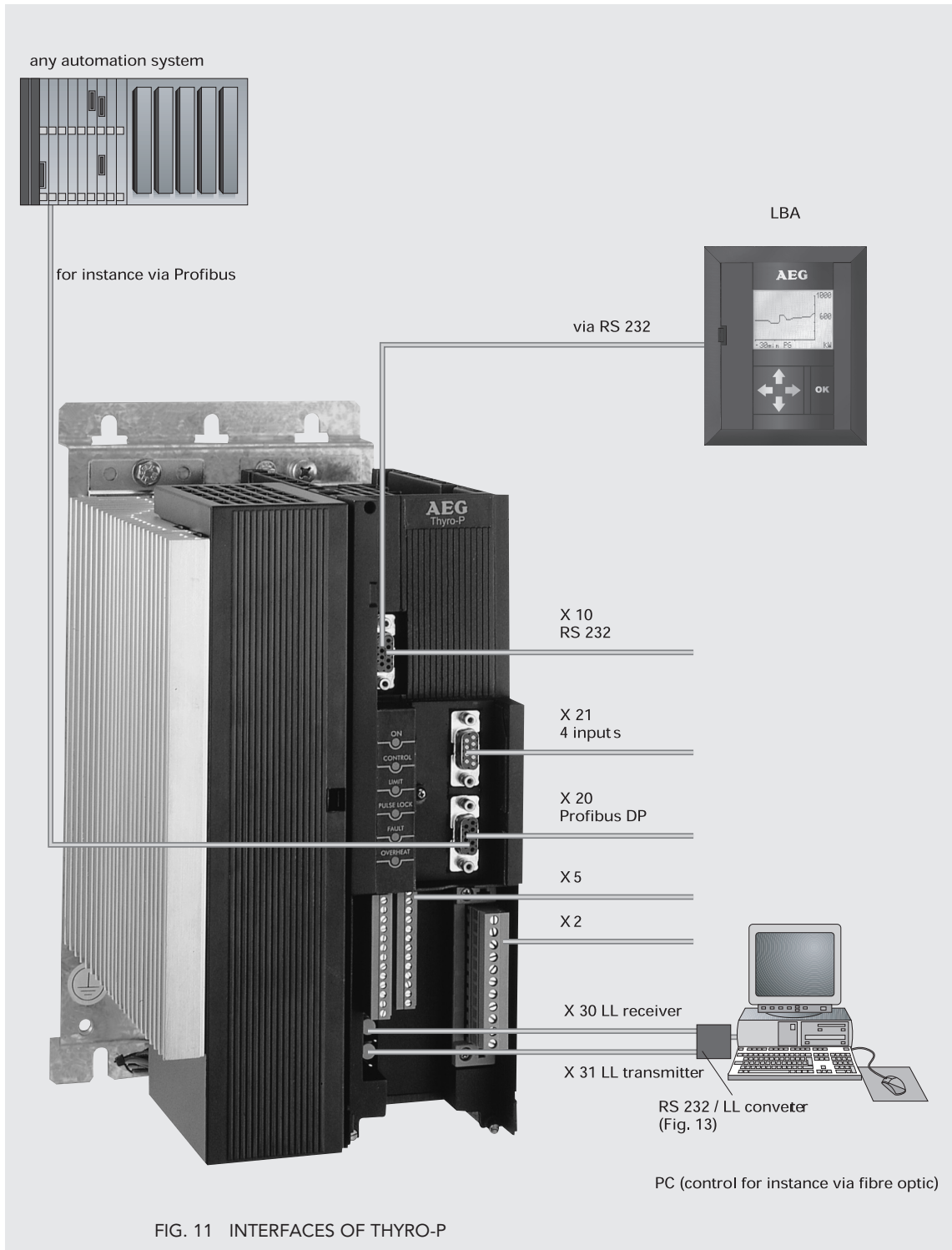

FIG. 11 INTERFACES OF THYRO-P

With the Power Controller Thyro-P, the following interfaces may be used for this (see also fig. 11 on previous page):

- X10, RS 232
- X30, fibre optic receiver
- X31, fibre optic transmitter

as well as optional interfaces, for instance

- X20, bus interface, e.g. for Profibus DP

All internally processed data like current, voltage, power, set point value, limitations, etc. may be enquired, processed and modified during operation (online operation) in master-slave process. Under assistance of corresponding automation technology, it is possible to do without connection of process controls, potentiometers, instruments, LBA, etc.

The existing interfaces may operated simultaneously, so that for instance the following system configuration would be possible: a stored-program control via Profibus supplies the set points, a PC visualizes (fibre optic interface/Thyro-Tool Family) the data and on location the device status and selected operating values are displayed via LBA (using the RS 232).

Therefore, the Power Controller Thyro-P is transparent to all levels of production and the process may therefore be securely handled.

5.1 RS 232 INTERFACE

The isolated RS 232 interface is provided for direct connection of an LBA (with cabinet installation kit also indirect via cable) or a PC. Setting of parameters of the interface is performed using Thyro-Tool Family or LBA. The default baud rate is set to 9600 baud, no parity, 8 data bits, 1 stop bit.

The following illustration shows connection of a Thyro-P to a PC using the RS 232 interface (also possible via fibre optic or Profibus).

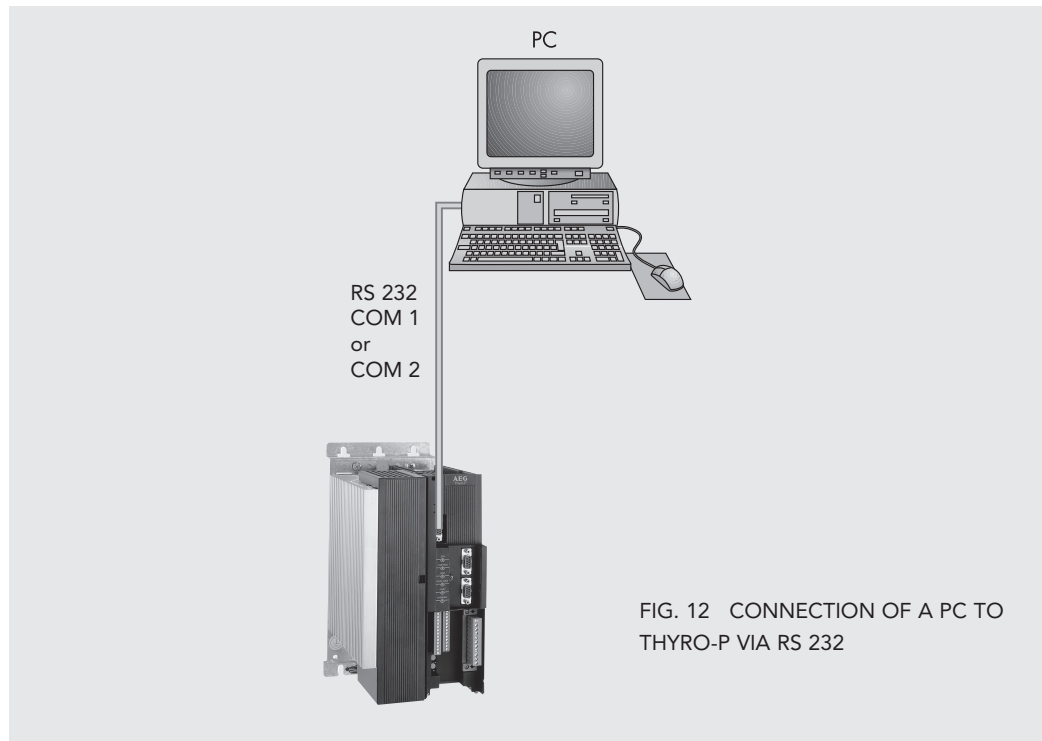
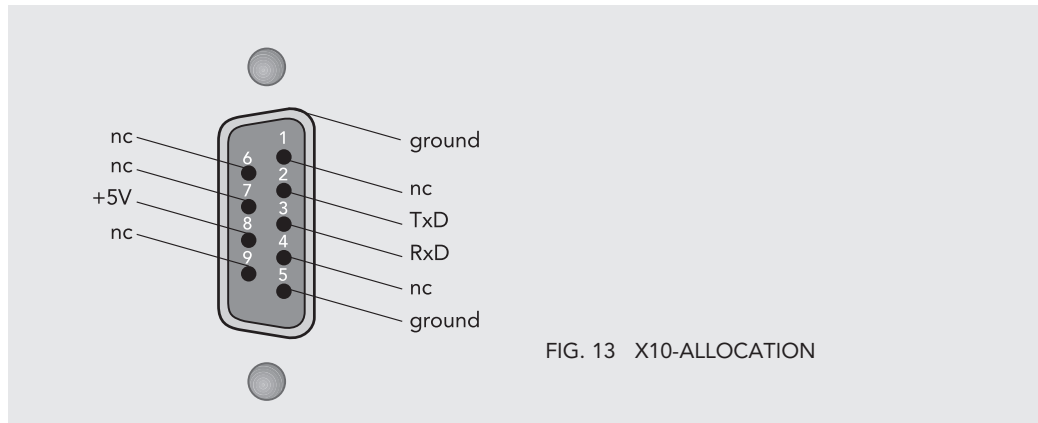

FIG. 12 CONNECTION OF A PC TO THYRO-P VIA RS 232

For connecting the PC, an RS 232 cable is required. On the Thyro-P side, a 9-pin sub-D plug and on the PC side a 9-pin sub-D socket must be available.

The connecting socket X10 of the Power Controller is allocated as follows (1:1 connection):



ATTENTION

The LBA receives its power supply (+5V) via pin 8 of the socket X10. It is imperative that this voltage is not short-circuited. Otherwise, damage to Thyro-P may be incurred.

If a PC is connected to the RS 232 interface, then this pin should be left unconnected, since it is not needed for data transfer.

Generally, all devices with an RS 232 interface may communicate with Thyro-P. The protocol used may simply be created by the user himself.

For this purpose, a detailed description of the protocol used may be requested from AEG PS (refer to application document).

5.2 FIBRE OPTIC INTERFACE

This widely used interface (LL, X30 LLE blue, X31 LLS grey) for quick and secure data transfer is fitted to Thyro-P as standard and enables connection of up to 998 Thyro-P Power Controllers. Due to the good interference immunity, larger distances can be bridged and data can be transferred at higher speeds.

To install a fibre optic system, the following interface components can be used.

5.2.1 FIBRE OPTIC DISTRIBUTION SYSTEM

Using the components described below, a complete fibre optic system for connection of up to 998 Thyro-P may be created.

SIGNAL CONVERTER RS 232 / FIBRE OPTIC

Connection of the fibre optic to the PC interface (RS 232) is performed using the fibre optic / RS 232 signal converter shown below. Power supply is via the plug-in power supply enclosed.

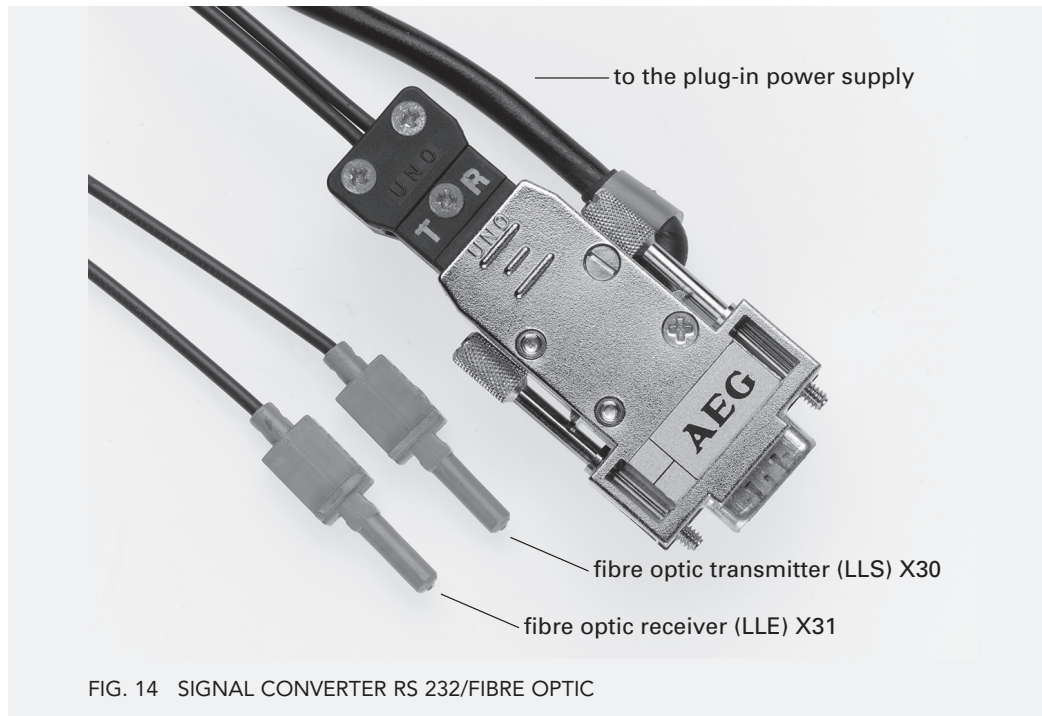

FIG. 14 SIGNAL CONVERTER RS 232/FIBRE OPTIC

LLV.V

The fibre optic distributor supply LLV.V is the basic component for the fibre optic system. It serves to connect star distributors and to amplify the light signals received. Its power supply is sufficient for supply of five fibre optic distribution components of the type LLV.4.

The amplification of LLV.V in the fibre optic data path is sufficient for increasing the distance for each LLV.V by about 50 m, so that overall longer transmission paths are possible then.

LLV.4

The fibre optic distributor LLV.4 is connected to the base component LLV.V. It is able to distribute the optical signal to respectively receive from four connections and therefore multiplies the signal from the computer to Thyro-P by four units each. The maximum distance from LLV.4 to Thyro-P should not exceed about 25 m.

In case of optimum installation conditions (number of bends, connection mounting, etc.), the distances stated in the following table may be realized:

DEVICE	PC	LLV.V	LLV.4	THYRO-P
PC	--	50 m	--	25 m
LLV.V	50 m	50 m	--	25 m
LLV.4	--	50 m	--	25 m
Thyro-P	25 m	25 m	25 m	--

TAB. 23 FIBRE OPTIC DISTANCES

The following figure shows the fibre optic system with LLV, Thyro-P and PC.

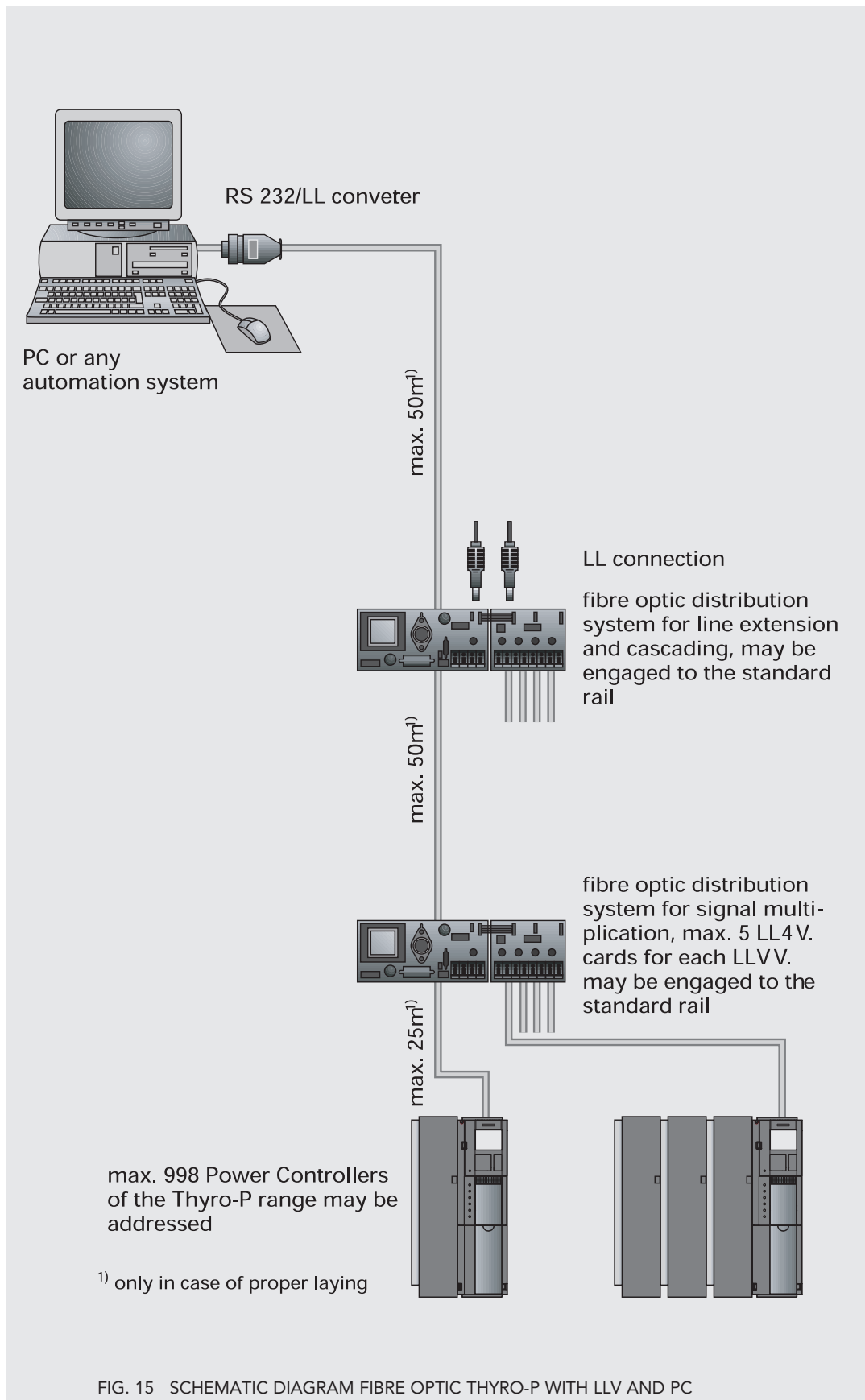

FIG. 15 SCHEMATIC DIAGRAM FIBRE OPTIC THYRO-P WITH LLV AND PC

5.3 BUS INTERFACES (OPTION)

The control device of Thyro-P may be optionally fitted with interface cards for interfaces customary for the industry. In case of bus systems not listed, please enquire about availability.

5.3.1 PROFIBUS-DPV1

With a Profibus interface card (order no. 2000000393) it is possible to connect the Thyro-P to a wide ranging Bus system. For use of Thyro-P in an automation network with SIEMENS PCS7, software modules are available (at SIEMENS).

The Profibus slot card is plugged into the front of the control device and is immediately ready to operate after parametrization. In case of Profibus control, the control device should be supplied separately, so that should the power supply be switched off, the Power Controller is not interrupted resulting in an alarm message. The connector supplied must be removed (see chapter 4.2).

Three 24V inputs are additionally available, which may be polled via Profibus (for instance for switching state, power interruptor, monitoring the cabinet ventilator, monitoring the cabinet door, etc.).

The Profibus option includes

- 1 Profibus slot card
- 1 diskette for configuration of Thyro-P as Profibus slave,
- 1 covering frame for secure fixing of the slot card,
- 1 short instruction booklet



ATTENTION

The mounting of the option must be made in voltageless state.

GENERAL

Up to 125 slaves may be connected to a Profibus system. 32 slaves are possible for each Profibus segment. Coupling of individual segments is performed using so-called repeaters. Profibus systems may be organized as line, bus or tree structures. Besides the usual electrical connections (RS 485 technology), it is possible, for instance in highly interfering environment (magnetic fields, etc.) to use fibre optic as transmitting medium.

The line length depends on the respective transmission rate and is possible up to 1200m (also refer to the table).

Baud rate [kbits/s]	9.6	19.2	45.45	93.75	187.5	500	1500
Line length [m]	1200	1200	1200	1200	1000	400	200

TAB. 24 PROFIBUS BAUD RATES

PROFIBUS SLOT CARD

The Profibus slot card (about 86 x 70 mm) has two 9-pin SUB-D sockets on the front side. On the other side, there is a 9-pin SUB-D plug to be inserted into the Thyro-P control device. The Profibus slot card for instance contains driver circuits, galvanic separation for the bus circuit as well as a microcontroller for controlling bus access and other functions.

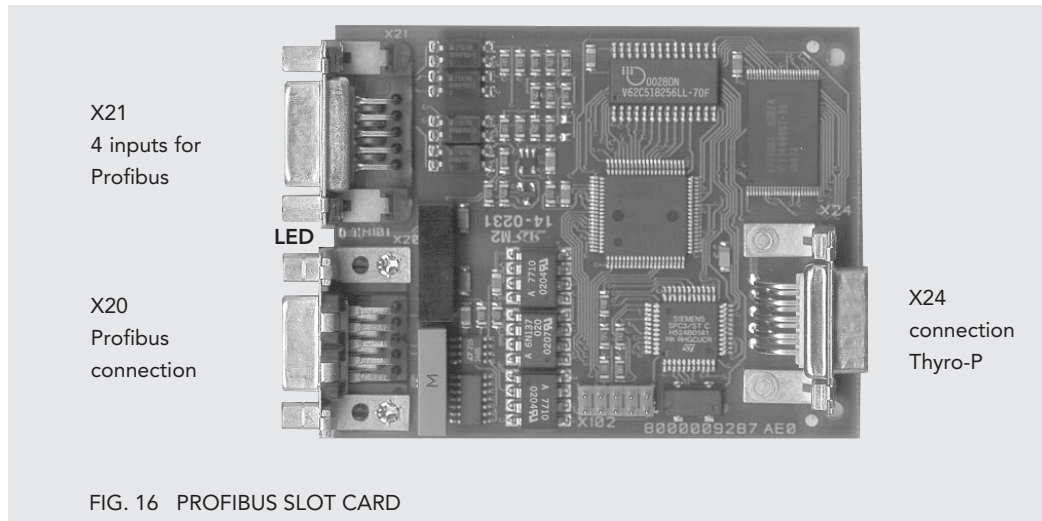

FIG. 16 PROFIBUS SLOT CARD

After switching on Thyro-P, it will automatically detect the Profibus slot card. On the Thyro-P side, the device address must be set using the LBA or Thyro-Tool Family.
After configuration of the Profibus, Thyro-P is ready for operation on the Profibus.

CONNECTION TO THE PROFIBUS

The Profibus is connected to the 9-pin SUB-D socket X20. The usual plug (see table) or an OLP module (fibre optic) may be used for this.

The following plugs are recommended

ORDER NO. (SIEMENS)	DESCRIPTION:
6ES7 972-0BA40-0XA0	35° cable outlet including terminating resistors
6ES7 972-0BA30-0XA0	30° cable outlet without terminating resistors

For connection of the OLP modules (Profibus via fibre optic), a 5V power supply voltage is provided on the Profibus socket X20, pin 6. This bears a load of at max. 80mA.

TERMINATING RESISTORS

Within a Profibus segment, terminating resistors must be switched in the first and the last device. Because the Profibus slot card does not have internal terminating resistors, plugs containing integrated terminating resistors must be used and these must be switched on, if the first or last device is a Thyro-P!



REMARK

FAILURE OF THYRO-P OR PROFIBUS

If the Profibus fails during operation of Thyro-P, set points or actual values cease to be transmitted. Thyro-P continues to operate using the last current set point. If the Thyro-P fails as Profibus slave, then this fault is signaled on the Profibus system. If the RESET function on Thyro-P is activated, there will also be a RESET period the Bus function is interrupted.

Additional digital inputs

On the 9-pin SUB-D plug X21, the Profibus slot card has four digital inputs which are mapped to the 1st data byte of the reply from Thyro-P.

Pin assignment of the plug is as follows:

X21 ASSIGNMENT

1	PE (potential earthing)
2	ground M1
3	input 0/M1
4	input 1/M1
5	ground M24 / 24V supply for the Profibus card
6	ground M2
7	input 2/M2
8	input 3/M2 / special function = Motorpoti enable
9	+24V / 24V supply for the Profibus card

* Loading: $I_{X5.1,20} + I_{X5.2,20} + I_{X21,9} \leq \text{max. } 80\text{mA}$

TAB. 25 PIN ASSIGNMENT X21

The inputs 0 and 1 refer to ground M1, the inputs 2 and 3 refer to ground M2. To connect simple transmitters like limit switches, etc., a 24V power supply is also available. The input IN3 (PIN 8) is taken up by a special function.

Therefore, connection could for instance be as follows:

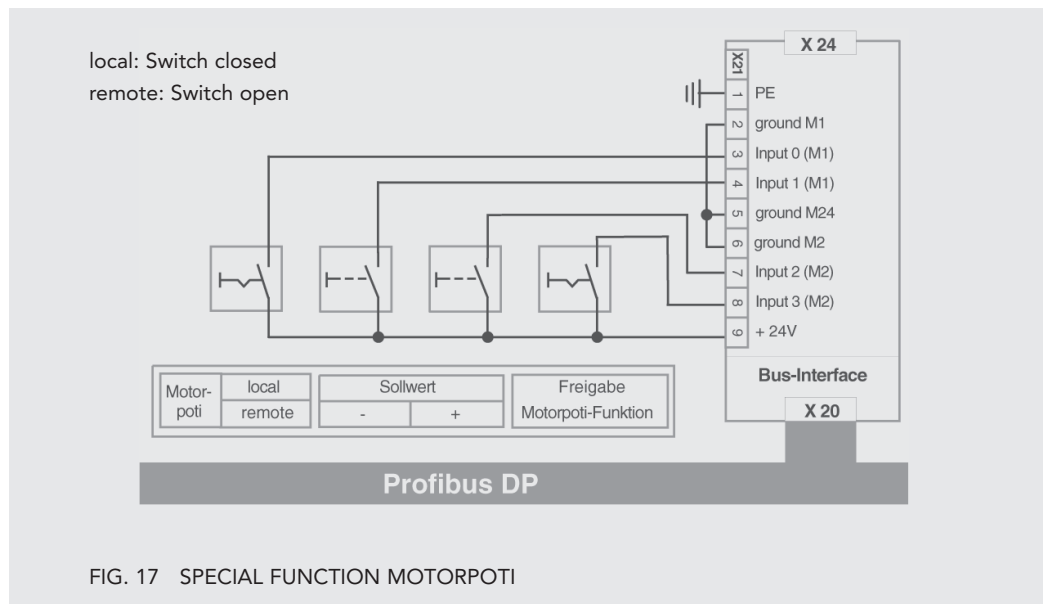

FIG. 17 SPECIAL FUNCTION MOTORPOTI

If the special function Motorpoti is not applied, 3 free inputs of the Bus card are available. Set out below are the most important features of the Profibus option.

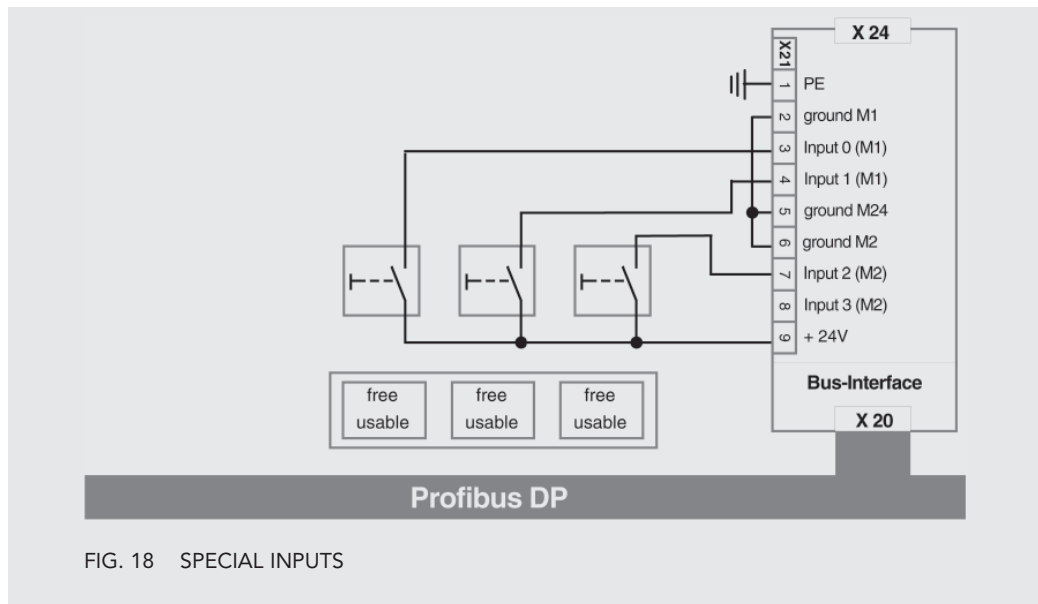

FIG. 18 SPECIAL INPUTS

DETAILS OF THE PROFIBUS

Further details for use of Thyro-P with Profibus like

- organization of the messages
- parameter setting messages
(setting which data is to be cyclically transmitted)
- cyclical parameters (REAL data format)
- PKW interface, PNU table
- diagnostic indications
- GSD file

are described in a separate file on the Profibus data media.

The user can choose between different configurations and establish, for instance, the number of actual values etc. within them.

HARDWARE CHARACTERISTICS

The Profibus card has the following characteristics:

- transmission speeds of 9600 Baud up to 12 MBaud
- RS 485 galvanically separated up to 140V
- optional fibre optic interface
- 5V power supply, pin 6 max. 80mA
- 3 additional inputs
- 24V stored-program controller compatible
- current consumption <20mA
- galvanically separated (140V)

IDENTIFICATION NO.

A Thyro-P with Profibus slot card corresponds to a Profibus device according to EN 50170.

Ident no.:	06B4
Associated GSD-file:	PSS106B4.GSD

5.3.2 MODBUS RTU

With the Modbus interface component a connection is possible between Thyro-P and the wide-spread Modbus RTU. The slot card is inserted into the front of the control device and is ready for operation after parameterization. The control device must be supplied separately so that should the power supply be switched off, the Power Controller is not interrupted resulting in an alarm message (see chapter 4.2).

As shown in both previous figures, Modbus RTU can also use either the special function Motorpoti or three available digital inputs (24V DC).

Using commercial gateways it is possible to interconnect to various field buses as well as Ethernet systems with TCP/IP protocol.

Further information can be obtained from the operating instructions of the Modbus option.

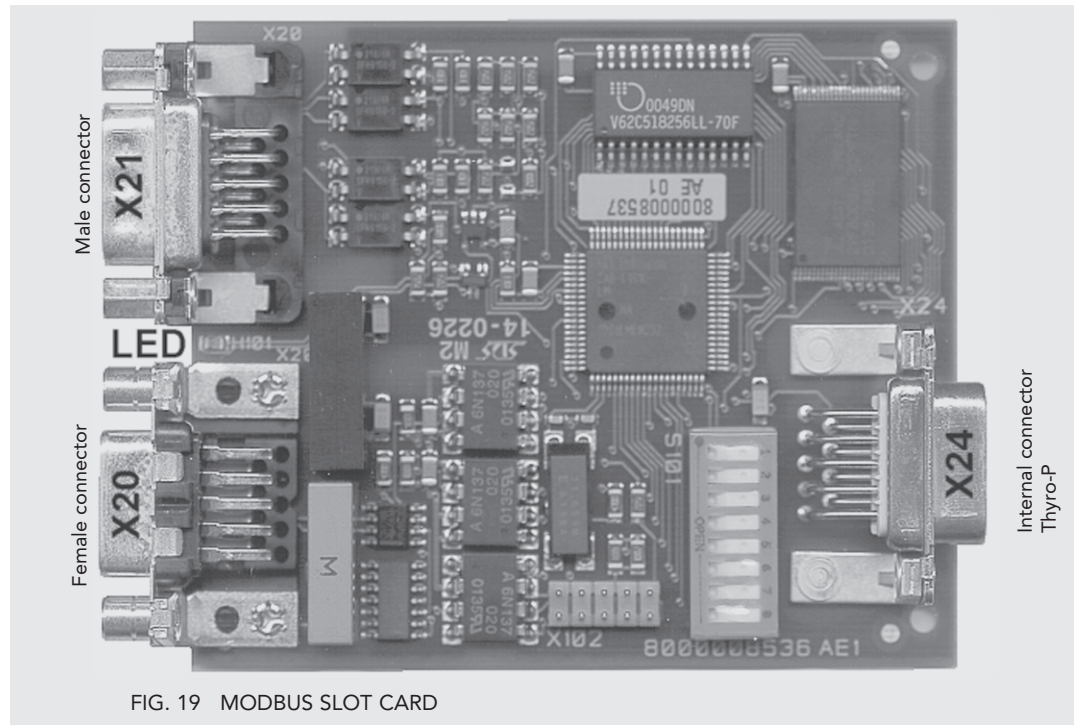

FIG. 19 MODBUS SLOT CARD

5.3.3 DEVICENET

With the DeviceNet interface component (order no. 2.000.000.394) a connection is possible between Thyro-P and the wide ranging bus system. The slot card is inserted into the front of the control device and is ready for operation after parameterization. The control device must be supplied separately so if the power supply is switched off, the power controller is not interrupted resulting in an alarm message (see chapter 4.2).

DeviceNet can also use either the special function motor potentiometer or three available digital inputs (24 V DC).

6. MAINS LOAD OPTIMIZATION

Mains load optimization (option) is possible in multiple controller applications. The application of mains load optimization offers substantial advantages: reduction of mains load peaks and mains reactions, smaller sizes (for instance for the transformer, feed and other installations) and associated smaller operating and investment cost. Mains load optimization is possible in a dynamic (ASM process) and a static (SYT-9 process) mode. Both modes may also be used in combination with the Thyristor Power Controller Thyro-M.

6.1 SYT-9 PROCEDURE

A process for static mains load optimization: minimizes mains load peaks and associated mains reaction shares. For the SYT-9 process, set points and load changes are not automatically included in mains load optimization.

The SYT-9 process requires an additional component. For Thyro-P, it should only be employed in connection with already installed controllers (Thyro-M, Thyrotakt MTL) under SYT-9 process.

Then, the pulse of the SYT card must be connected to the terminal X5.1:18 and ground to X5.1:14. On the Thyro-P Power Controller, the jumper X201 (behind X5) must be pulled off. For this purpose, the texts BAL 00180 and operating instructions SYT-9 must be observed as described under Thyro-M.

THYRO-P NO.	SYT9 NO. 1	THYRO-P NO.	SYT9 NO. 1
1	X5.2.5 - A10	1	X5.2.18 - C10
2	- A12	2	- C12
3	- A14	3	- C14
4	- A16	4	- C16
5	- A18	5	- C18
6	- A20	6	- C20
7	- A22	7	- C22
8	- A24	8	- C24
9	- A26	9	- C26

Connection of up to 9 Thyro-P at one SYT9-Module

6.2 SOFTWARE SYNCHRONIZATION

By means of different settings in the storage location SYNC_Adresse, a different startup of the individual Power Controllers (counter x 10ms) may be achieved. The counter is set to 0 after switching on the mains or RESET. While the counter is running, the Power Controller is switched passive, as during controller lock.

It is possible to enter values in SYNC_Adresse larger than the clock time T0. Then, startup of the Power Controller is only during the next clock time. For instance, in an emergency power plant, slow switching of the total load is possible. The max. delay is 65535 x 10ms. This value also forms the base setting for the ASM process.

6.3 ASM PROCEDURE (PATENTED)

In systems, in which several equal Power Controllers are operated in the operating mode TAKT, the ASM process may be sensibly used for dynamic and automatic mains load optimization in multiple Power Controller applications. This patented world premiere independently minimizes mains load peaks and therefore mains reaction shares during the current process. In case of the ASM process (automated synchronization of multiple controller applications), changes in set point and load (for instance due to temperature-dependent load) are included in mains load optimization online. Especially when using heating elements with a large aging effect, which during new operation have high current amplitudes with short startup time, lower investment cost may be achieved. For the ASM

process the controller requires an ASM control device. An additional burden resistor is used for all controllers. Schematic wiring of Power Controllers for the ASM process can be seen in the following illustration:

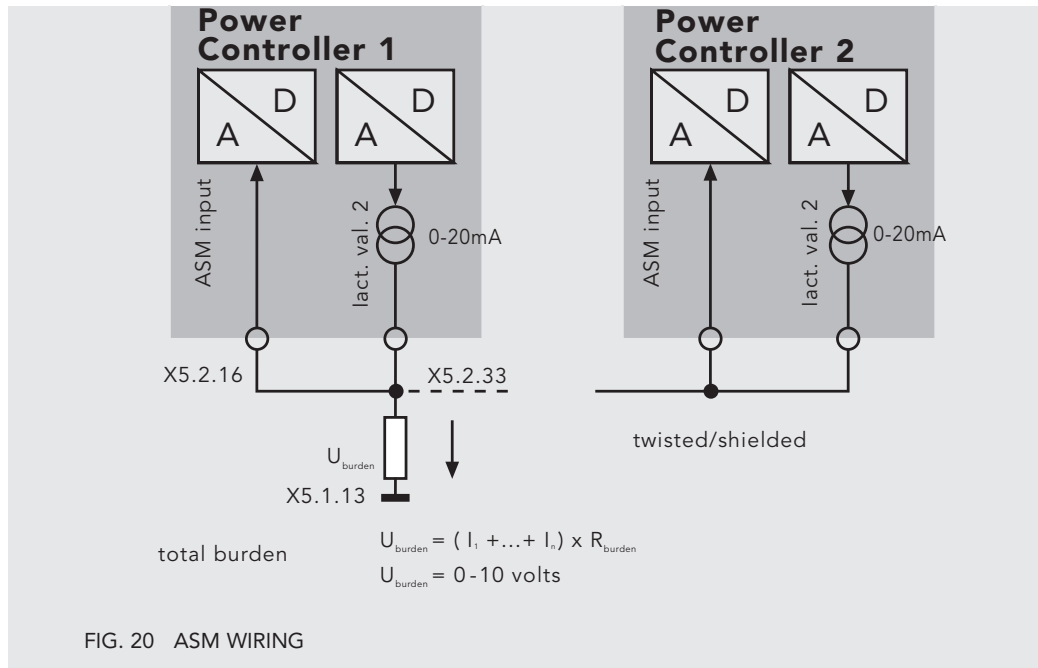

When using the ASM option, the analog output 2 (X5.2.33 against ground X5.1.13) becomes an output proportionate to the current during the on-period T_s . All Power Controllers connected to synchronization work on the same external burden. The burden resistor is calculated approximately as

$$R_{burden} [\text{k}\Omega] = 10V / (n \times 20\text{mA}) \quad n = \text{number of Power Controller}$$

The burden voltage is measured at the ASM input. The Power Controller searches within the clock control the place with the lowest mains load.

Due to this automated, independent procedure, the process chain is ensured through the temperature control circuit and the Power Controller without effects; negative effects like flicker and sub-harmonics of the mains frequency are balanced out during a current dynamic process. In this case, unfavorable short-term overlapping may occur, for instance after set point jumps or voltage swing. The application document ASM-procedure gives further information on this.

7. CONNECTING DIAGRAMS

7.1 1-PHASE

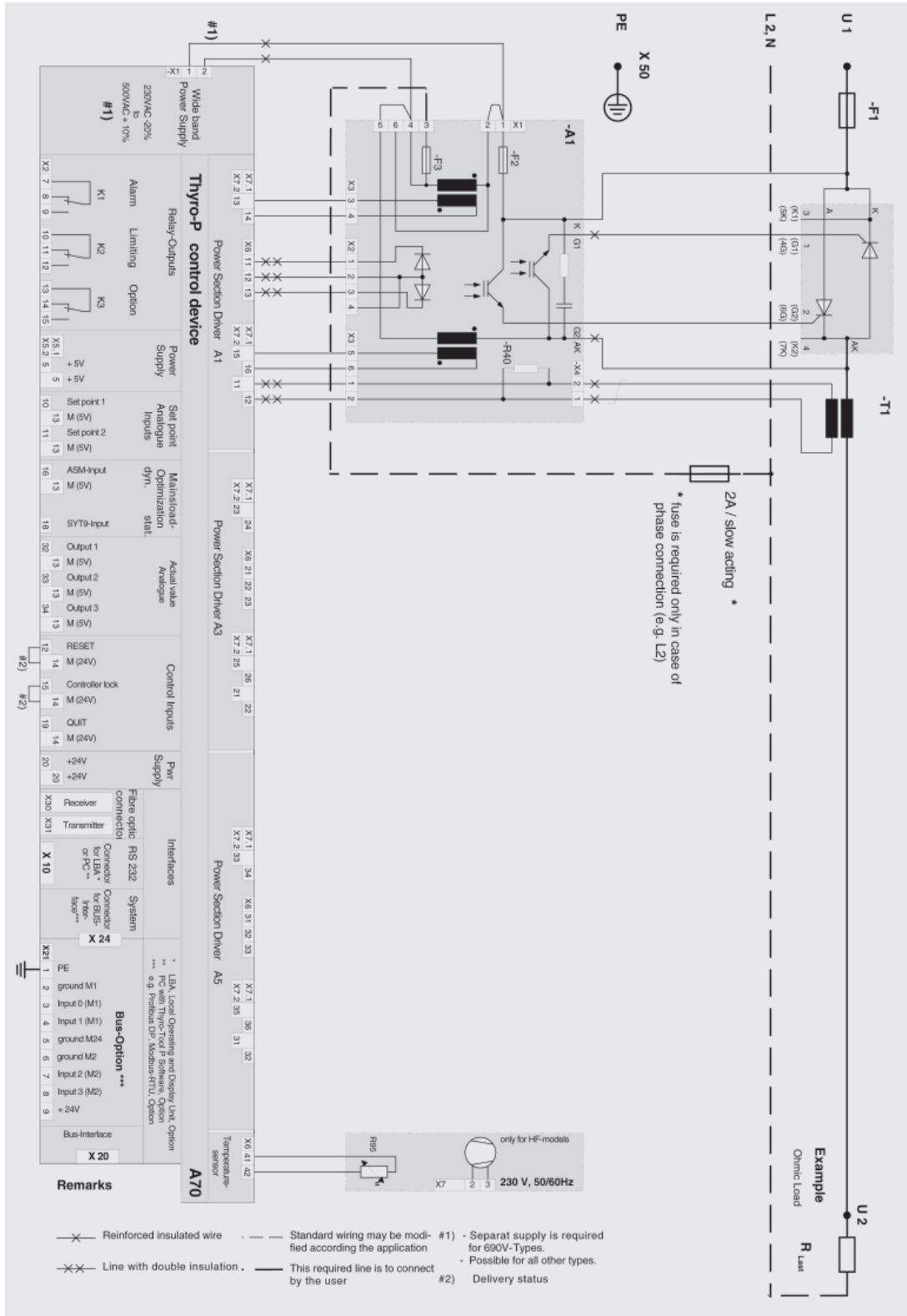

7.2 2-PHASE

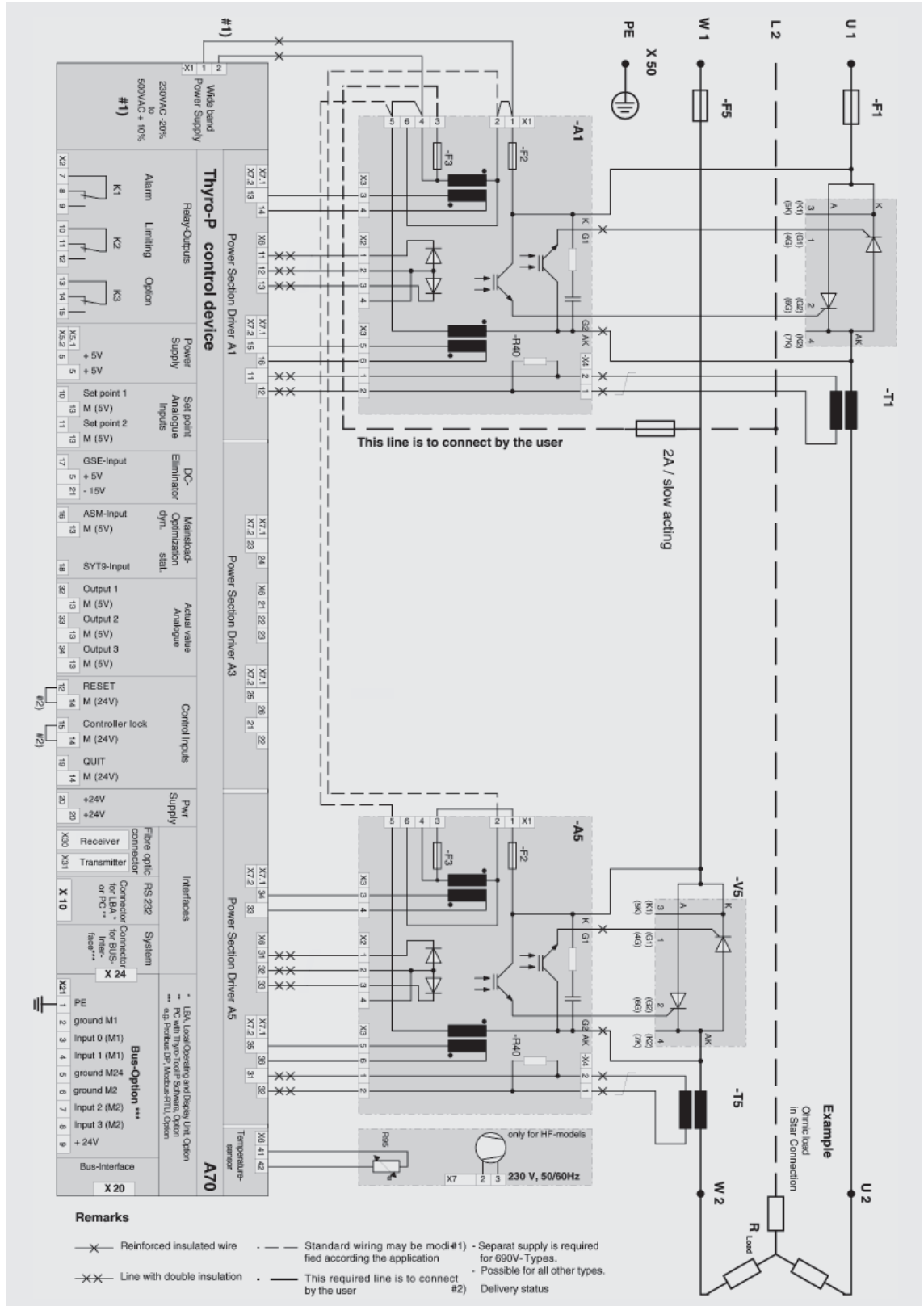

Remarks

- X- Reinforced insulated wire
- X-X- Line with double insulation
- - - Standard wiring may be modified according to the application
- - - This required line is to connect by the user
- - - Separat supply is required for 690V-Types.
- - - Possible for all other types.
- #1) Delivery status
- #2) Delivery status

7.3 3-PHASE

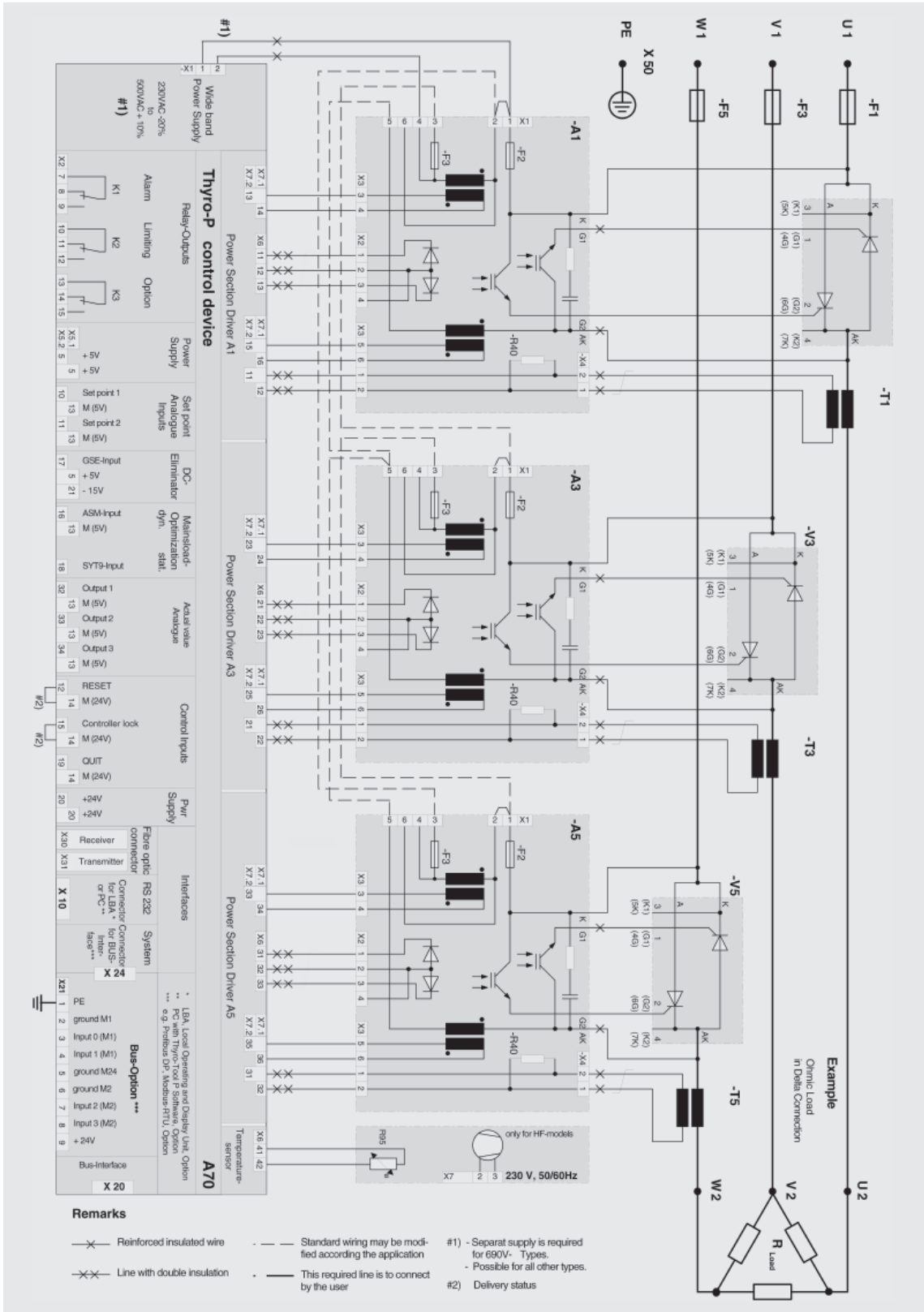

8. SPECIAL REMARKS

8.1 INSTALLATION

The installation orientation of Thyro-P is vertical, so that ventilation of the thyristors fastened to heat sinks is ensured. In case of cabinet mounting, additionally sufficient ventilation of the cabinet must be ensured. The distance between Power Controller and the bottom should be at least 100mm; the distance to the ceiling 150mm. The devices may be installed next to each other without lateral distance. Heating up of the device by heat sources must be avoided. The dissipation of the Power Controller is stated in the table chapter type overview.

Grounding must be performed according to local regulations of the utility company (grounding screw for protective conductor connection).

8.2 COMMISSIONING

The device must be connected to the mains and the associated load according to the wiring diagrams.



REMARK

It must be observed that with 1P, terminal A1 X1:3 is connected to the U2 on the opposite load side. With 2P it must be observed that terminal A1 X1:3 is connected to the non-controlled phase. Depending on connection system of the load (star, delta, etc.), it must be ensured that the load voltage transformers in the power sections are wired correctly (terminal strip X1 of the power section). The correct terminals may be found in the connecting diagrams.

If the units 1P and 2P are operated at over 600 V and without load at the output side, voltages can occur above input voltage at the connection points U2 and W2. In this case, an additional 690 V damping card is to be used. (Section 12, Accessories and Options)

On delivery, the device is parameterized adjusted to the respective power section. The operating mode TAKT is set. If a different operating mode is desired, then the user must set this using the LBA, PC, etc. Generally, the standard parameters (see menu list) should be reviewed and adjusted to the respective conditions for use by the user (for instance operating mode, control mode, limitations, monitoring, times, characteristics, actual value outputs, fault indications, relays, time and date, etc.).

Besides the load, some control signals must be connected as well (refer to chapter 4). The following signals are always required for operation of the device:

Set point	(terminal 10 or 11/or via interfaces)
RESET	(on ground, on terminal 12, jumper set as standard)
Regular inhibit	(on ground, on terminal 15, jumper set as standard)

If the RESET is not connected, then the device is in reset state and is not operating (LED „ON“ shows red light), i.e. no communications is possible via interface. Further details of the RESET are described in chapter 4.4. If the regulator inhibit is not connected, then the device is fully operable, but the power section is only controlled using the values of the minimal limitations (LED „PULSE LOCK“ is on). Further details on the regulator inhibit may be found in the chapter 4.5 of the same name.

**ATTENTION**

The controller lock may also be set via the interfaces!

**ATTENTION**

The control device is to be operated only with casing.

8.3 SERVICE

The devices delivered have been tested according to the state of the art and have been produced to a high quality standard (DIN EN ISO 9001). Still, should any faults or problems occur, our 24 hour service hotline, Tel.: +49 (0) 2902/763-100 is available to you.

8.4 CHECKLIST

No frontside LED is on:

- for 690V devices, the power supply for the control device A70 to be provided by the customer is missing. (Attention, maximum nominal input voltage 500V)
- check voltage at terminal X1.1 and X1.2 of the control device A70
- check semiconductor fuse and the fuses F2 and F3 on the controller card A1.

**CAUTION**

In any case, set the device voltageless and check if it is voltageless
Terminal X1.3 on the controller card A1 not connected.

- if the semiconductor fuse is defective, then the following parameters must be checked in case of transformer load for the operating modes TAKT and SSSD:
phase angle of the first half-wave (phase angle 1) = 60 degrees;
possibly optimize. Check for the model type 1P, 2P or 3P
Menu: Parameters/Operating mode/Number of phases controlled 1 2 3)

No load current

- RESET X5.2.12 is not jumpered for X5.1.14 (LED ON lit in red)
- supply voltage of the control device outside of the tolerable range
- controller lock X5.2.15 is not jumpered for X5.1.14 (LED PULSE LOCK is on)
- no set point is set. Using the LBA, check the total set point (effective total), or measure set point on X5.2.10 and X5.2.11.
- set points are not cleared (STD, Local, Remote, ANA)
- parameterization of the set point inputs 20mA, 5V, 10V, does not matched to output of the temperature controller
- parameters STA and STE of the control characteristic are wrong
- parameter for linkage of the set points is not set to "ADD"
- parameters IEMA, UEMA, PMA are set too small
- controller parameters T_i and K_p are set too large.

**CAUTION**

Check fuses on the controller cards A1, A3, A5. In any case, set the device voltageless and check if it is voltageless.

- Load connection by the customer is missing (only for type 1P).
Check connection on A1 terminal X1.3.
- Check synchronization voltage at the control device A70 at the terminal blocks X7.1 and X7.2.

The thyristors are set to full scale

- Was the set point set via motor potentiometer function? Check value using the LBA.
- Check the control characteristic (STA, STE, ADD).
- Controller feedback signal available? Check current transformer and voltage transformer connections at the terminal blocks X7.1 and X7.2.
- Parameters TSMI and H_IE, $U_{rms\ min}$, $I_{rms\ min}$, P_{min} are larger than 0.
- Controller parameters Ti and Kp are set too small.
- Parameters IEMA, UEMA, PMA are set too large or the load current is too small.
- Possibly thyristor short-circuit



REMARK

In case the load current is too small (connection of a test load), the device must be parameterized for U, U² control or "without control". The regulation limits continue to remain active. Connection of a minimal load (e.g. 100W lightbulb) is necessary.

Measures in case of other malfunction

- Evaluation of incident register (data logger) with LBA or Thyro-Tool
- Comparison of actual parameters of Thyro-P with parameters in type list.
- Comparison of actual parameters of Thyro-P with the system dependent parameters stored in the PC.
- Correct number of controlled phases ((parameters)
- With activated trouble signal relay Evaluation which faults led to a response, eliminate the fault.

9. TYPE OVERVIEW

9.1 TYPE RANGE 400 VOLTS

TYPE VOLTAGE 230-400 VOLTS

TYPE CURRENT (A)	TYPE POWER (KVA)		DISSIPATION (W)	DIMENSIONS (MM)			WEIGHT (NET ABOUT KG)	DIM. DRAW. (NO.)	TEMP. CHARACTE- RISTIC (NO.)	CURRENT TRANSF. T1	BURDEN RESISTOR R40 (Ω)	SEMICON- DUCTOR FUSE* F1 (A)	UL _{US} 508
	230V	400V		W	H	D							
THYRO-P 1P													
37 H	8	15	105	150	320	229	6	260	1	100/1	2.70	50	UL _{US}
75 H	17	30	130	150	320	229	6		1	100/1	1.30	100	
110 H	25	44	175	150	320	229	6		2	100/1	0.91	180	
130 H	30	52	190	200	320	229	8	263	2	150/1	1.10	200	
170 H	39	68	220	200	320	229	8		2	200/1	1.10	315	
280 HF	64	112	365	200	370	229	9	265	2	300/1	1.00	350	UL _{US}
495 HF	114	198	595	174	414	340	15	266	3	500/1	1.00	630	
650 HF	149	260	750	174	414	340	15		3	700/1	1.00	900	
1000 HF	230	400	1450	240	685	505	35	268	4	1000/1	1.00	2x1000	
1500 HF	345	600	1775	240	685	505	35		5	1500/1	1.00	4x900	
2100 HF	483	840	2600	521	577	445	50	270	6	2000/1	0.91	4x1000	
2900 HF	667	1160	3400	603	577	470	62	271	7	3000/1	1.00	4x1500	
THYRO-P 2P													
37 H	15	25	175	225	320	229	10	272	1	100/1	2.70	50	UL _{US}
75 H	30	52	220	225	320	229	10		1	100/1	1.30	100	
110 H	44	76	310	225	320	229	10		2	100/1	0.91	180	
130 H	52	90	350	325	320	229	12	275	2	150/1	1.10	200	
170 H	68	118	410	325	320	229	12		2	200/1	1.10	315	
280 HF	111	194	700	325	397	229	15	277	2	300/1	1.00	350	UL _{US}
495 HF	197	343	1150	261	414	340	22	278	3	500/1	1.00	630	
650 HF	259	450	1465	261	414	340	22		3	700/1	1.00	900	
1000 HF	398	693	2865	410	685	505	54	280	4	1000/1	1.00	2x1000	
1500 HF	597	1039	3510	410	685	505	54		5	1500/1	1.00	4x900	
2000 HF	796	1385	4800	526	837	445	84	282	6	2000/1	1.00	4x1000	
2750 HF	1095	1905	6200	603	837	470	107	283	7	3000/1	1.00	4x1500	
THYRO-P 3P													
37 H	15	25	330	300	320	229	14	284	1	100/1	2.70	50	UL _{US}
75 H	30	52	400	300	320	229	14		1	100/1	1.30	100	
110 H	44	76	540	300	320	229	14		2	100/1	0.91	180	
130 H	52	90	560	450	320	229	17	287	2	150/1	1.10	200	
170 H	68	118	650	450	320	229	17		2	200/1	1.10	315	
280 HF	111	194	1070	450	397	229	20	289	2	300/1	1.00	350	UL _{US}
495 HF	197	343	1800	348	430	340	30	290	3	500/1	1.00	630	
650 HF	259	450	2265	348	430	340	30		3	700/1	1.00	900	
1000 HF	398	693	4370	575	685	505	74	292	4	1000/1	1.00	2x1000	
1500 HF	597	1039	5335	575	685	505	74		5	1500/1	1.00	4x900	
1850 HF	736	1281	6900	526	1094	445	119	294	6	2000/1	1.00	4x1000	
2600 HF	1035	1801	8700	603	1094	470	152	295	7	3000/1	1.10	4x1500	

* number of fuses per path of power section, built in

9.2 TYPE RANGE 500 VOLTS

TYPE VOLTAGE 500 VOLTS

TYPE CURRENT (A)	TYPE POWER (KVA)	DISSIPATION (W)	DIMENSIONS (MM)			WEIGHT (NET ABOUT KG)	DIM. DRAW. (NO.)	TEMP. CHARACTERIS- TIC (NO.)	CURRENT TRANSF. T1	BURDEN RESISTOR R40 (Ω)	SEMICON- DUCTOR FUSE* F1 (A)	UL 508
			W	H	D							
THYRO-P 1P												
37 H	18	105	150	320	229	6	260	1	100/1	2.70	50	
75 H	38	130	150	320	229	6		1	100/1	1.30	100	
110 H	55	175	150	320	229	6		2	100/1	0.91	180	
130 H	65	190	200	320	229	8	263	2	150/1	1.10	200	UL
170 H	85	220	200	320	229	8		2	200/1	1.10	315	
280 HF	140	365	200	370	229	9	265	2	300/1	1.00	350	
495 HF	248	595	174	414	340	15	266	3	500/1	1.00	630	
650 HF	325	750	174	414	340	15		3	700/1	1.00	900	RU US
1000 HF	500	1450	240	685	505	35	268	4	1000/1	1.00	2x1000	
1500 HF	750	1775	240	685	505	35		5	1500/1	1.00	4x900	
2100 HF	1050	2600	521	577	445	50	270	6	2000/1	0.91	4x1000	
2900 HF	1450	3400	603	577	470	62	271	7	3000/1	1.00	4x1500	

THYRO-P 2P

37 H	32	175	225	320	229	10	272	1	100/1	2.70	50	
75 H	65	220	225	320	229	10		1	100/1	1.30	100	
110 H	95	310	225	320	229	10		2	100/1	0.91	180	
130 H	112	350	325	320	229	12	275	2	150/1	1.10	200	UL
170 H	147	410	325	320	229	12		2	200/1	1.10	315	
280 HF	242	700	325	397	229	15	277	2	300/1	1.00	350	
495 HF	429	1150	261	414	340	22	278	3	500/1	1.00	630	
650 HF	563	1465	261	414	340	22		3	700/1	1.00	900	RU US
1000 HF	866	2865	410	685	505	54	280	4	1000/1	1.00	2x1000	
1500 HF	1300	3510	410	685	505	54		5	1500/1	1.00	4x900	
2000 HF	1732	4800	526	837	445	84	282	6	2000/1	1.00	4x1000	
2750 HF	2381	6200	603	837	470	107	283	7	3000/1	1.00	4x1500	





THYRO-P 3P

37 H	32	330	300	320	229	14	284	1	100/1	2.70	50	
75 H	65	400	300	320	229	14		1	100/1	1.30	100	
110 H	95	540	300	320	229	14		2	100/1	0.91	180	
130 H	112	560	450	320	229	17	287	2	150/1	1.10	200	UL
170 H	147	650	450	320	229	17		2	200/1	1.10	315	
280 HF	242	1070	450	397	229	20	289	2	300/1	1.00	350	
495 HF	429	1800	348	430	340	30	290	3	500/1	1.00	630	
650 HF	563	2265	348	430	340	30		3	700/1	1.00	900	RU US
1000 HF	866	4370	575	685	505	74	292	4	1000/1	1.00	2x1000	
1500 HF	1300	5335	575	685	505	74		5	1500/1	1.00	4x900	
1850 HF	1602	6900	526	1094	445	119	294	6	2000/1	1.00	4x1000	
2600 HF	2251	8700	603	1094	470	152	295	7	3000/1	1.10	4x1500	





* number of fuses per path of power section, built in

9.3 TYPE RANGE 690 VOLT





TYPE VOLTAGE 690 VOLTS

TYPE CURRENT (A)	TYPE POWER (KVA)	DISSIPATION (W)	DIMENSIONS (MM)			WEIGHT (NET ABOUT KG)	DIM. DRAW. (NO.)	TEMP. CHARACTERISTIC (NO.)	CURRENT TRANSF. T1	BURDEN RESISTOR R40 (Ω)	SEMICON- DUCTOR FUSE* F1 (A)	
			W	H	D							
THYRO-P 1P												
80 H	55	125	200	320	229	8	263	1	100/1	1.20	100	
200 HF	138	260	200	370	229	9	265	2	200/1	1.00	250	
300 HF	207	360	174	414	340	15	266	3	300/1	1.00	350	
500 HF	345	625	174	414	340	15	266	3	500/1	1.00	630	
780 HF	538	910	240	685	505	35	268	4	1000/1	1.20	2x630	
1400 HF	966	1900	240	685	505	35		5	1500/1	1.00	4x700	
2000 HF	1380	3200	521	577	445	62	270	6	2000/1	1.00	4x900	
2600 HF	1794	3450	603	577	470	62	271	7	3000/1	1.10	4x1400	

THYRO-P 2P

80 H	35	225	325	320	229	12	275	1	100/1	1.20	100	
200 HF	239	485	325	397	229	15	277	2	200/1	1.00	250	
300 HF	358	640	261	414	340	22	278	3	300/1	1.00	350	
500 HF	597	1225	261	414	340	22	278	3	500/1	1.00	630	
780 HF	932	1700	410	685	505	54	280	4	1000/1	1.20	2x630	
1400 HF	1673	3750	410	685	505	54		5	1500/1	1.00	4x700	
1850 HF	2210	5700	526	837	445	84	282	6	2000/1	1.00	4x900	
2400 HF	2868	6400	603	837	470	107	283	7	3000/1	1.20	4x1400	

THYRO-P 3P

80 H	95	350	450	320	229	17	287	1	100/1	1.20	100	
200 HF	239	740	450	397	229	20	289	2	200/1	1.00	250	
300 HF	358	1020	348	430	340	30	290	3	300/1	1.00	350	
500 HF	597	1825	348	430	340	30	290	3	500/1	1.00	630	
780 HF	932	2740	575	685	505	74	292	4	1000/1	1.20	2x630	
1400 HF	1673	5600	575	685	505	74		5	1500/1	1.00	4x700	
1700 HF	2031	8000	526	1094	445	119	294	6	2000/1	1.10	4x900	
2200 HF	2619	9000	603	1094	470	152	295	7	3000/1	1.30	4x1400	

* number of fuses per path of power section, built in

10. SPECIFICATIONS

TYPE VOLTAGE	...P400...	230 volts -20%	to	400 volts +10%
	...P500...	230 volts -20%	to	500 volts +10%
	...P690...	500 volts -20%	to	690 volts +10%
MAINS FREQUENCY	all models	45Hz to 65Hz		
LOAD DESCRIPTION	ohmic load (minimum 100W) ohmic load R_{hot}/R_{cold} ratio up to 20 (MOSI operation) transformer load			
TRANSFORMER	The induction of the load side transformer should not exceed 1.45T in case of mains overvoltage when using grain-oriented, cold-rolled plates. This corresponds to a nominal induction of approx. 1.3T.			
OPERATING MODES	<p>TAKT = full oscillation clock principle = default setting for the models 1P, 2P and 3P</p> <p>VAR = phase-angle control = only for the models 1P and 3P</p> <p>SSSD = soft-start-soft-down; a combination of „VAR“ und „TAKT“, for the models 1P, 2P and 3P, i.e. reduced mains surge load</p>			
SET POINT INPUTS	<p>The Power Controller Thyro-P has 4 set point inputs. The set point inputs are indirectly connected to the mains (SELV, PELV).</p> <p>Set points 1, 2: external set point input signal ranges: 0(4) - 20 mA Ri about 250Ω max. 24mA* 0 - 5 V Ri about 8,8kΩ max. 12V 0 - 10 V Ri about 5kΩ max. 12V * refer to "ATTENTION" on page 16</p> <p>Set point 3: connection for fibre optic (LL) from the wuper-ordinate PC or automation system</p> <p>Set point 4: set point assignment via RS 232 (for instance LBA)</p> <p>The four set points are added internally and the total of the set points, for instance for power control, is proportionate to output power. For set point 2, there are different valuation options: it may be added to set point 1 or subtracted from set point 1.</p>			
ANALOG OUTPUTS	3 outputs: signal level 0-10 volts, 0-20mA or parameters may be set differently. The maximum burden voltage is 10V			
CONTROL CHARACTERISTIC	<p>The control characteristic is established by the maximum value of the dimensions to be controlled and the key values of the set point. Using these key values, the linear control characteristic may be set at will.</p> <p>Every controller (for instance temperature controller), whose output signal is in the range of 0-20mA/0-5V/0-10V may be easily adapted to the Power Controller.</p>			

CONTROL TYPES	Voltage control U_{rms} Voltage control U_{rms}^2 = default setting Current control I_{rms} Current control I_{rms}^2 Power control P Without control
PRECISION	U-control: Better than $\pm 0.5\%$ and ± 1 digit with reference to the end value.
LIMITATIONS	Voltage limitation U_{rms} Current limitation I_{rms} = default setting Effective power limitation P Peak current limitation, MOSI operation Upon reaching one of these limits, the LED "Limit" on the front panel of Thyro-P is on and the relay K2 is activated. (terminal strip X2, terminals 10/11/12)
Relay K1, K2, K3	Contact load: AC max: 250V/6A (1500VA) AC min: >10VA; DC max: 300V/0.25A (62.5W) DC min : 5V/20mA contactor material: AgCdO
WITH UL APPLICATIONS	AC max: 250V/4A
AMBIENT TEMPERATURE	35°C external cooling (F models) 45°C self air cooling At higher temperatures it is possible to operate with reduced type current:

COOLANT TEMPERATURE [°C]	$I/I_{RATED CURRENT}$	
	FORCED COOLING (VENTILATOR TYPES)	SELF COOLING
-10 bis 25	1.10	1.10
30	1.05	1.10
35	1.00	1.10
40	0.96	1.05
45	0.91	1.00
50	0.87	0.95
55	0.81	0.88

WITH UL APPLICATIONS UP TO +40°C

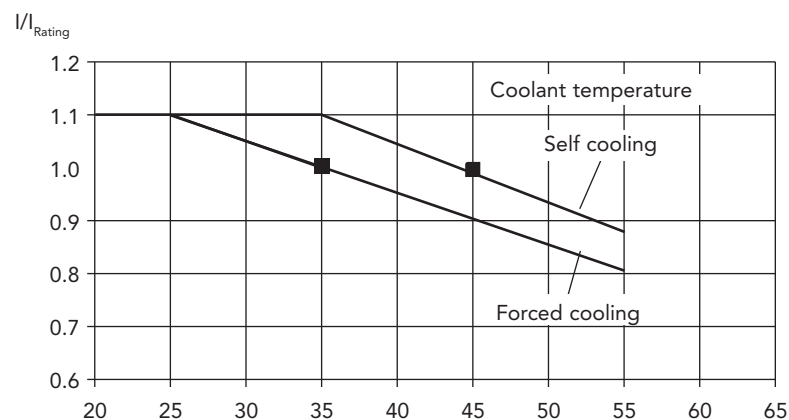

TABLE TERMINAL SCREWS	THYRO-P 1P, 2P, 3P	CONNECTOR	EARTHING SCREW
			U1, V1, W1, U2, V2, W2
	37H, 75H	M 6	M 6
	80H	M 8	M 10
	110H	M 6	M 6
	130H, 170H	M 8	M 10
	200HF, 280HF, 300HF	M 10	M 10
	495HF, 500HF, 650HF		
	780HF, 1000HF, 1400HF, 1500HF, 1700HF, 1850HF, 2000HF, 2100HF, 2200HF, 2400HF, 2600HF, 2750HF, 2900HF	M 12	M 12

WITH UL APPLICATIONS	POWER CONNECTION	USE ONLY 60°/75°C COPPER CONDUCTORS (UL SPECIFICATION)		
STUD TORQUE FOR TABLE TERMINAL SCREWS [Nm]	SCREW	MIN	RATED	MAX
	M 2	0.2	0.25	5.9
	M 6	3.0	4.4	22.5
	M 8	11.5	17.0	44
	M 10	22.0	33.0	75
	M 12	38.0	56.0	75.0
[Pound inches]	SCREW	MIN	RATED	MAX
	M 2	1.9	2.2	2.5
	M 6	26.1	38.9	52.2
	M 8	101.8	150.5	199.1
	M 10	194.7	292.1	389.4
	M 12	336.3	495.6	663.8

VENTILATOR 230 V, 50-60 HZ	THYRO-P (HF-TYPES)	TYPE CURRENT		AIR VOLUME [M ³ /H]	SOUND PRESS. IN 1 M DIST. [DBA]
		50HZ I [A]	60HZ I [A]		
	1P				
	200HF, 280HF	0.22	0.22	120	53
	300HF, 495HF, 500HF, 650HF	0.50	0.38	150	67
	780HF, 1000HF, 1400HF, 1500HF	0.55	0.60	580	75
	2000HF, 2100HF, 2600HF, 2900HF	1.00	1.20	2200	81
	2P				
	200HF, 280HF	0.50	0.38	200	67
	300HF, 495HF, 500HF, 650HF	0.50	0.38	230	67
	780HF, 1000HF, 1400HF, 1500HF	1.00	1.20	1200	81
	1850HF, 2000HF, 2400HF, 2750HF	1.00	1.20	2100	81
	3P				
	200HF, 280HF	0.50	0.38	260	67
	300HF, 495HF, 500HF, 650HF	1.20	0.85	450	72
	780HF, 1000HF, 1400HF, 1500HF	1.00	1.20	1600	81
	1700HF, 1850HF, 2200HF, 2600HF	1.00	1.20	2000	81

The ventilators (with HF types) must run with Thyro-P switched on.

Connection according to connecting diagrams.

Longer cooling fan start-up times can be expected when operating.

Thyro-P at temperatures below 10° C. Therefore the adjustment range of upstream protection devices should be at least the 2-fold of the indicated steady current.

11. DIMENSIONAL DRAWINGS

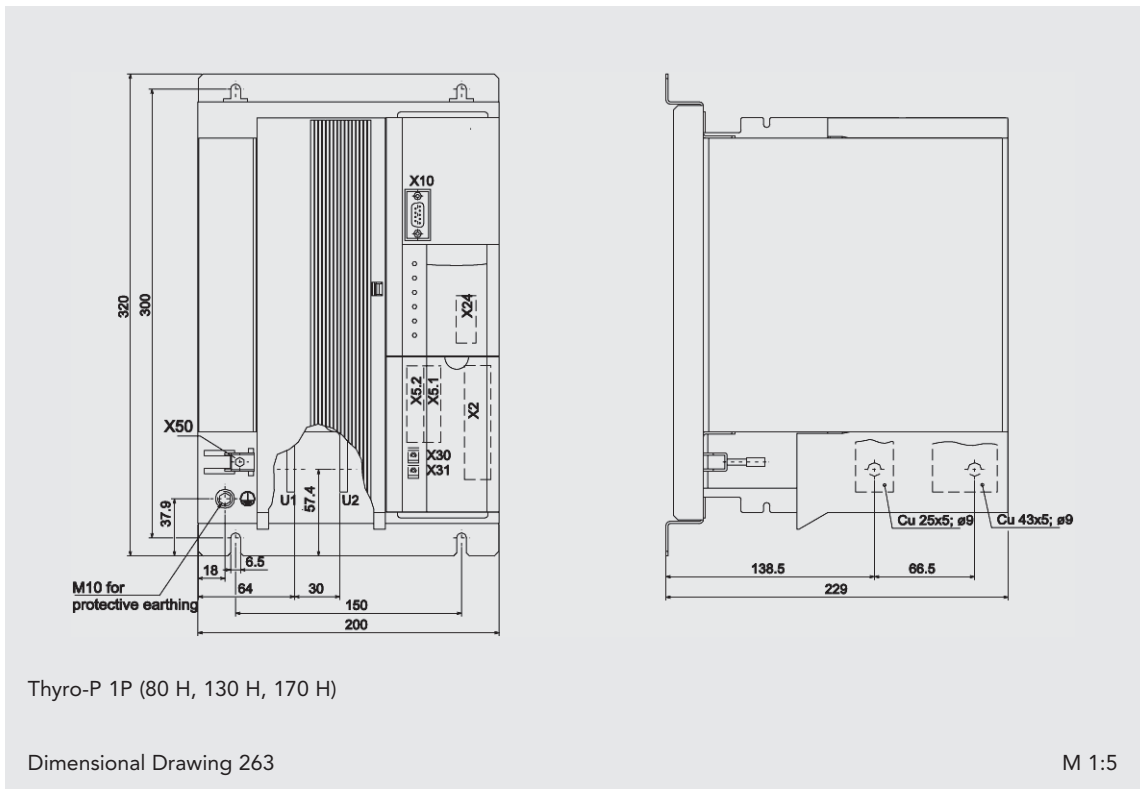
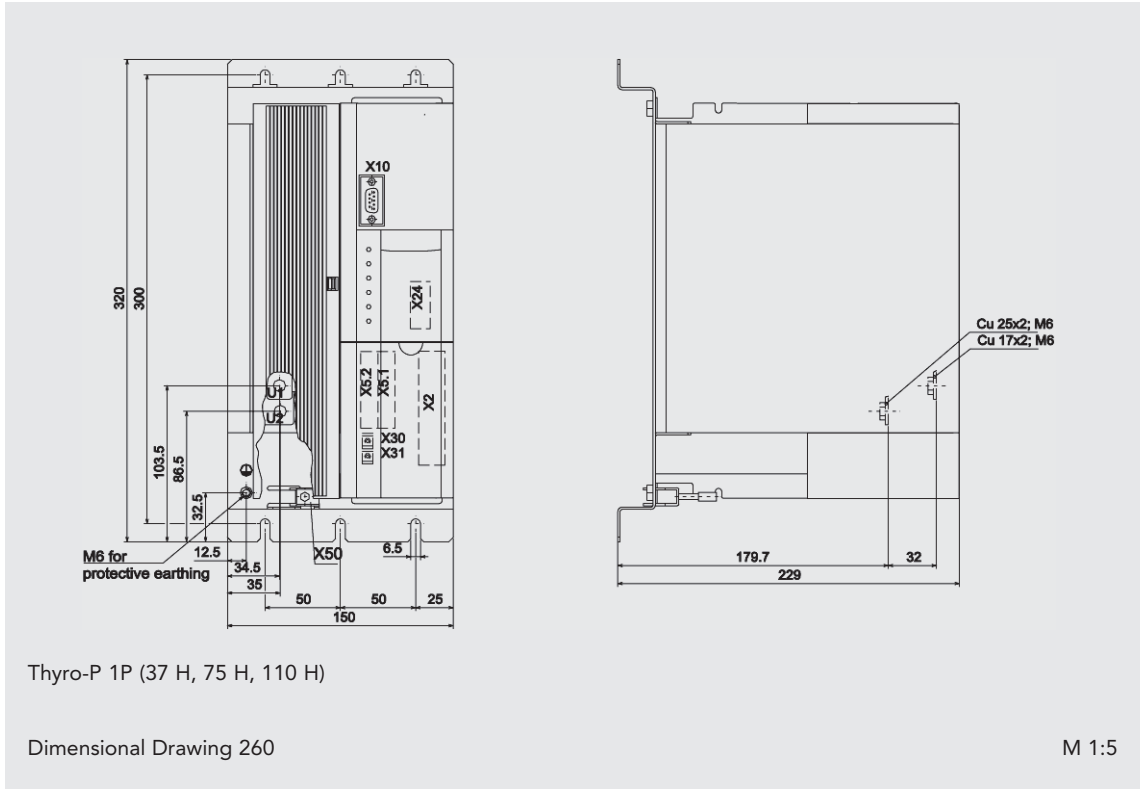

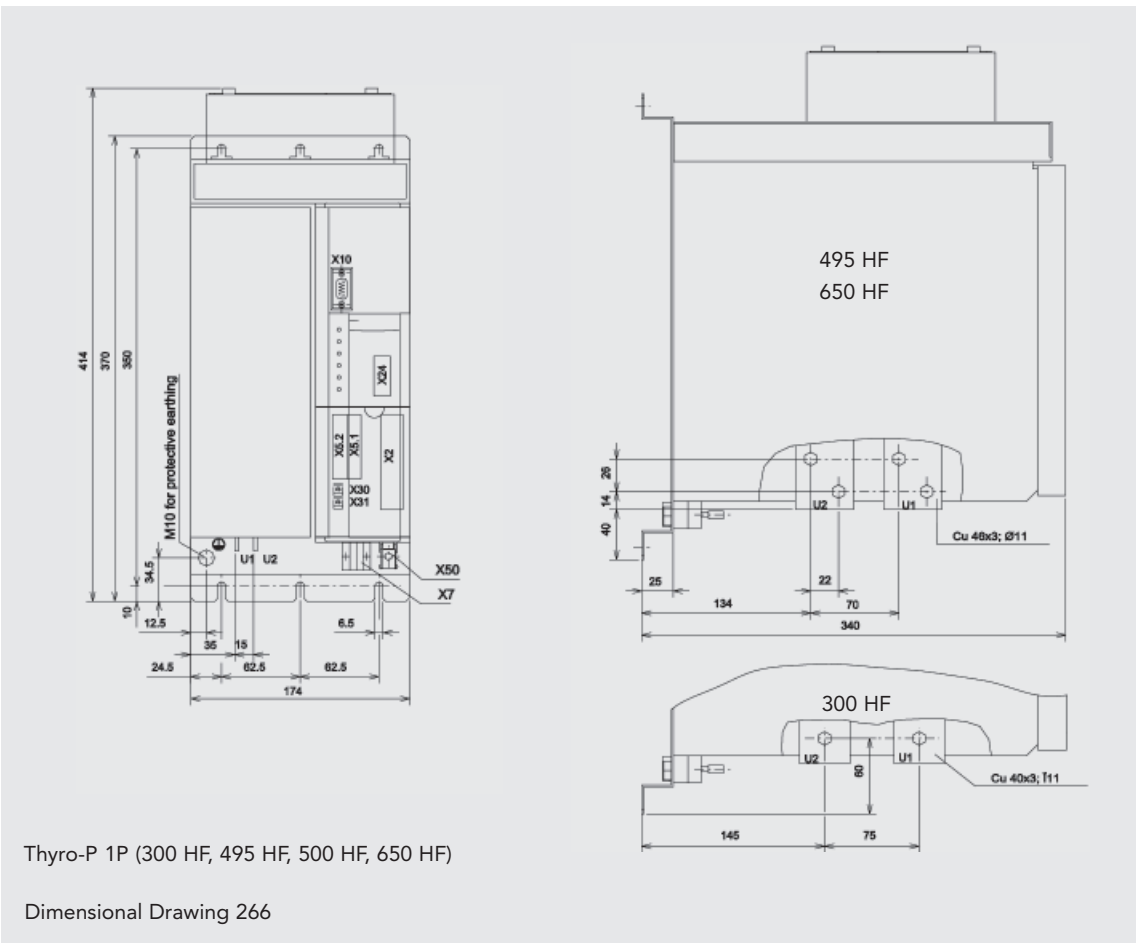
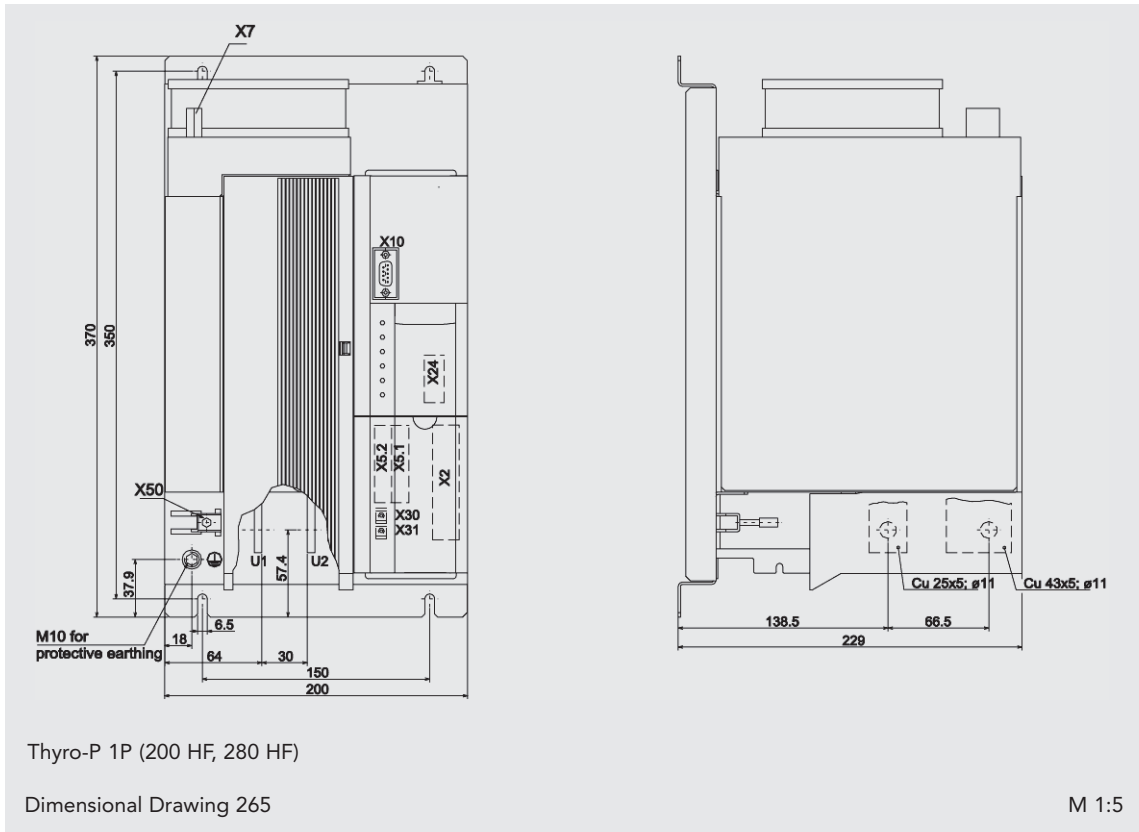

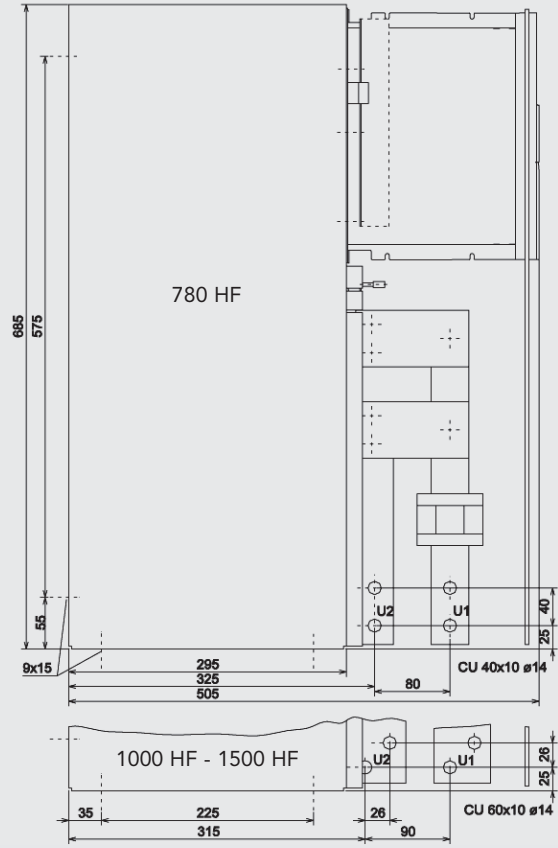
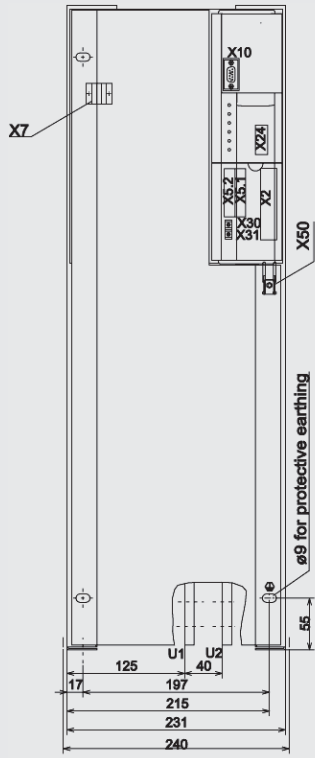

Thyro-P 1P (780 HF, 1000 HF, 1400 HF, 1500 HF)

Dimensional Drawing 268

M 1:8

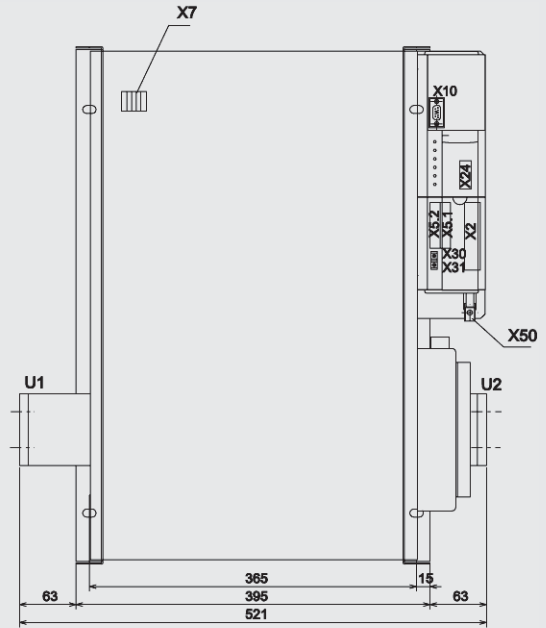
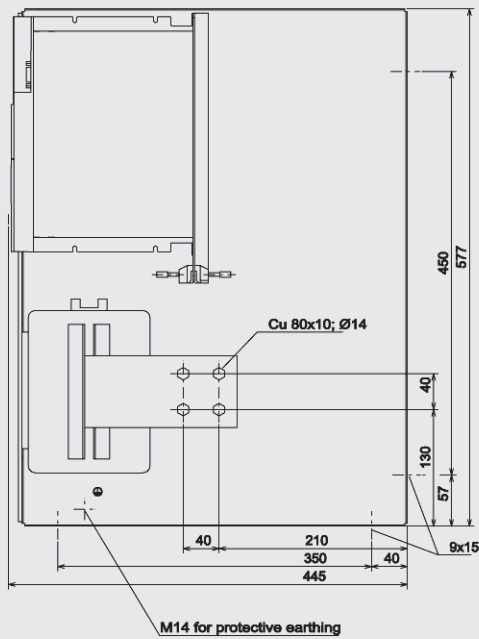

Thyro-P 1P (2000 HF, 2100 HF)

Dimensional Drawing 270

M 1:8

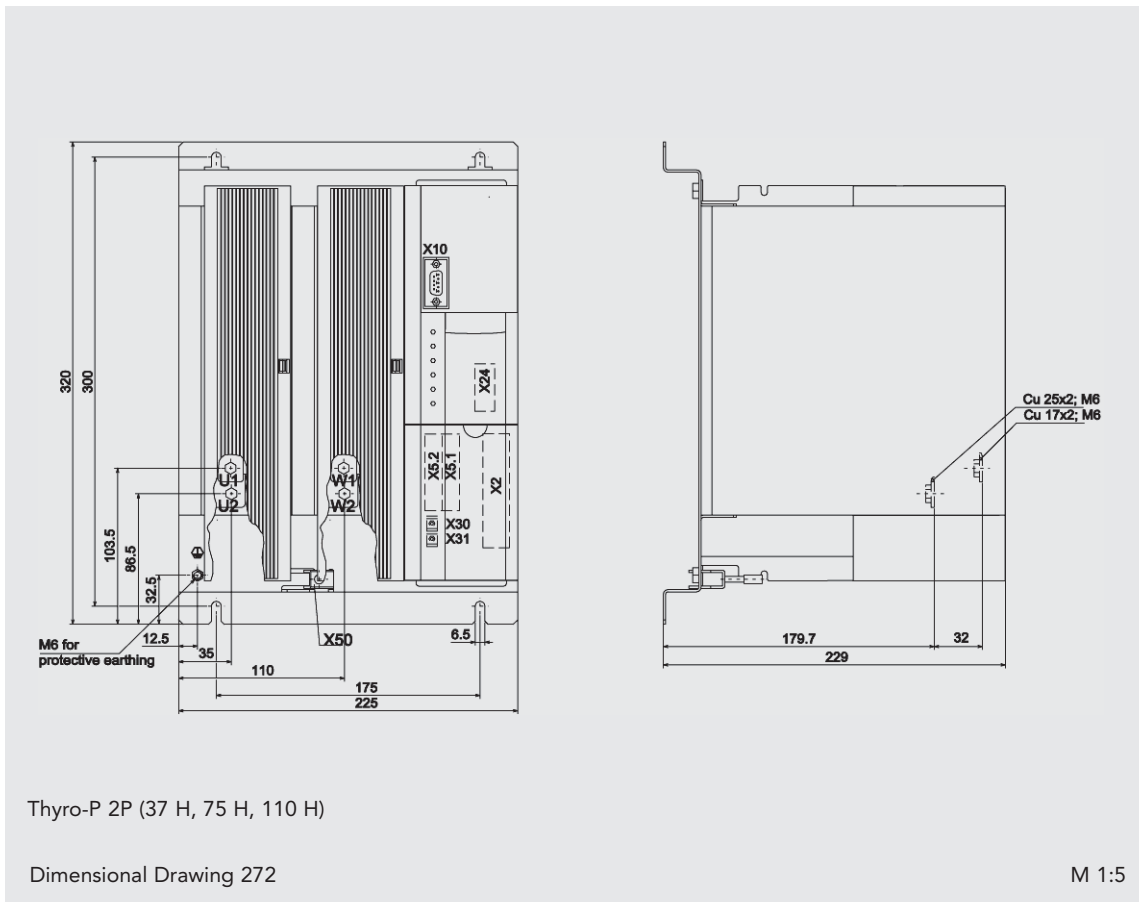
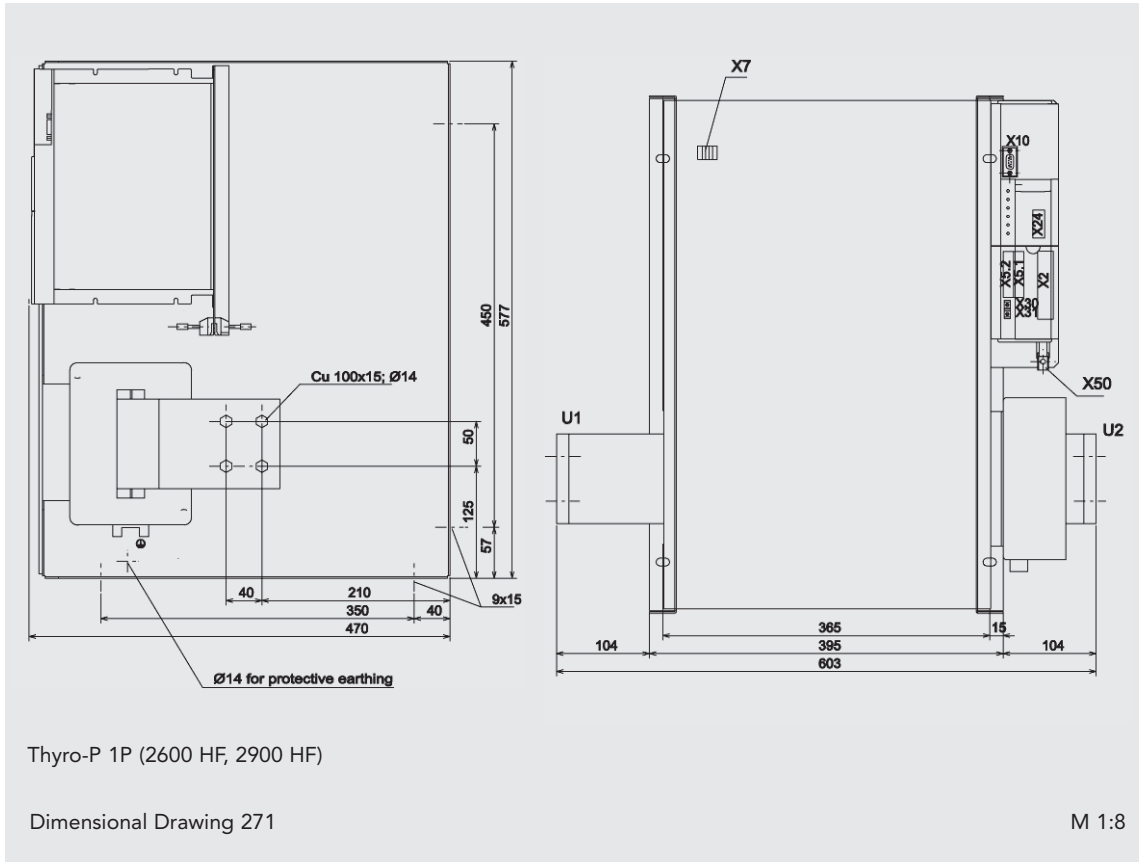

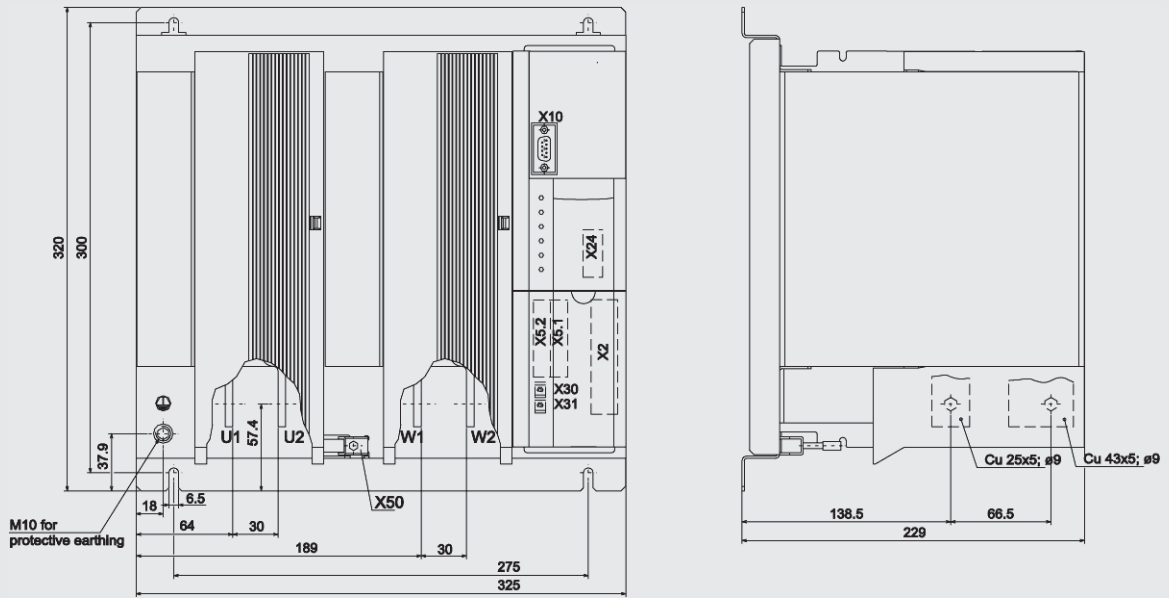

Thyro-P 2P (80 H, 130 H, 170 H)

Dimensional Drawing 275

M 1:5

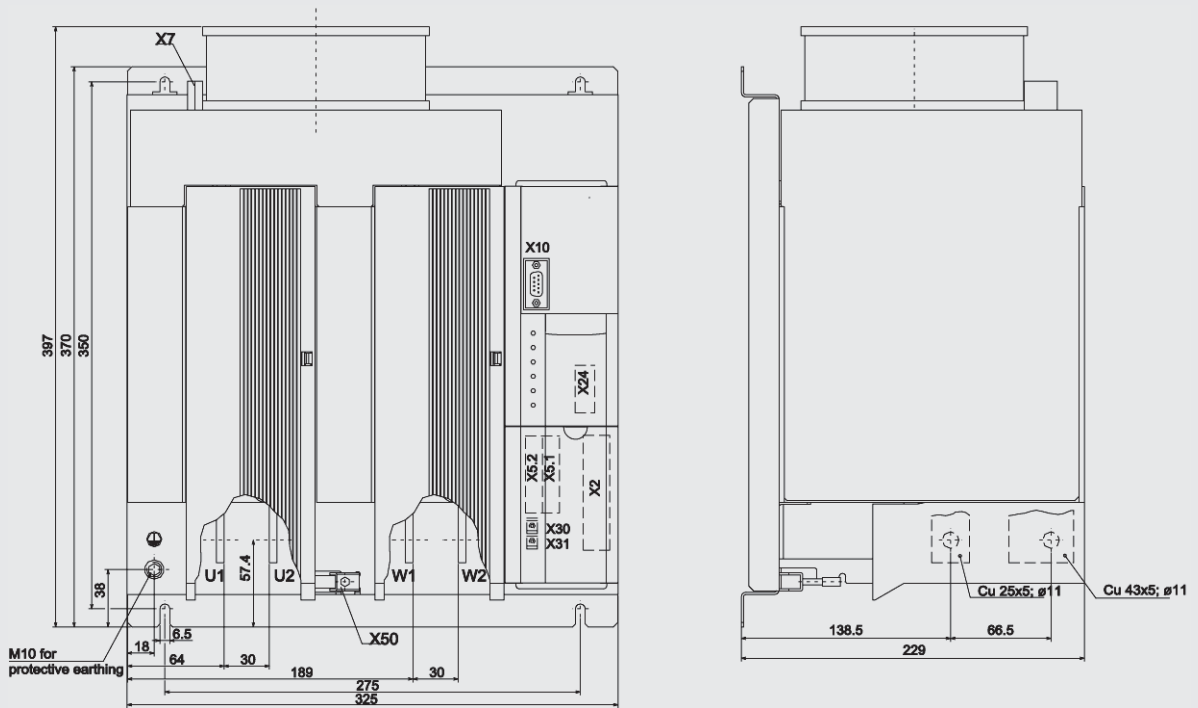

Thyro-P 2P (200 HF, 280 HF)

Dimensional Drawing 277

M 1:5

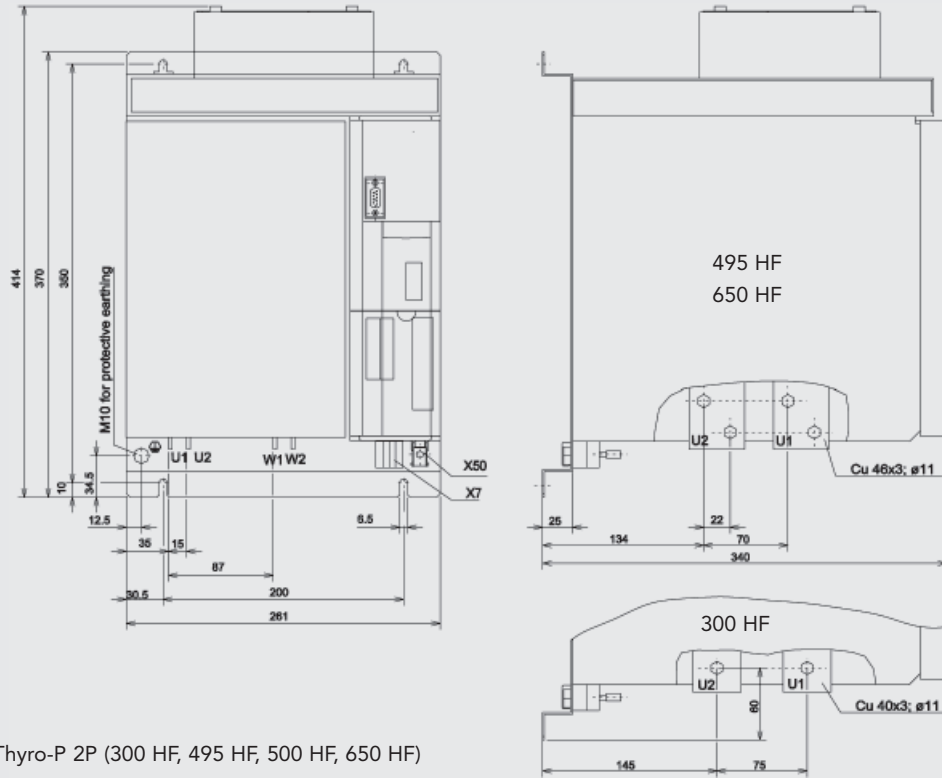

Thyro-P 2P (300 HF, 495 HF, 500 HF, 650 HF)

Dimensional Drawing 278

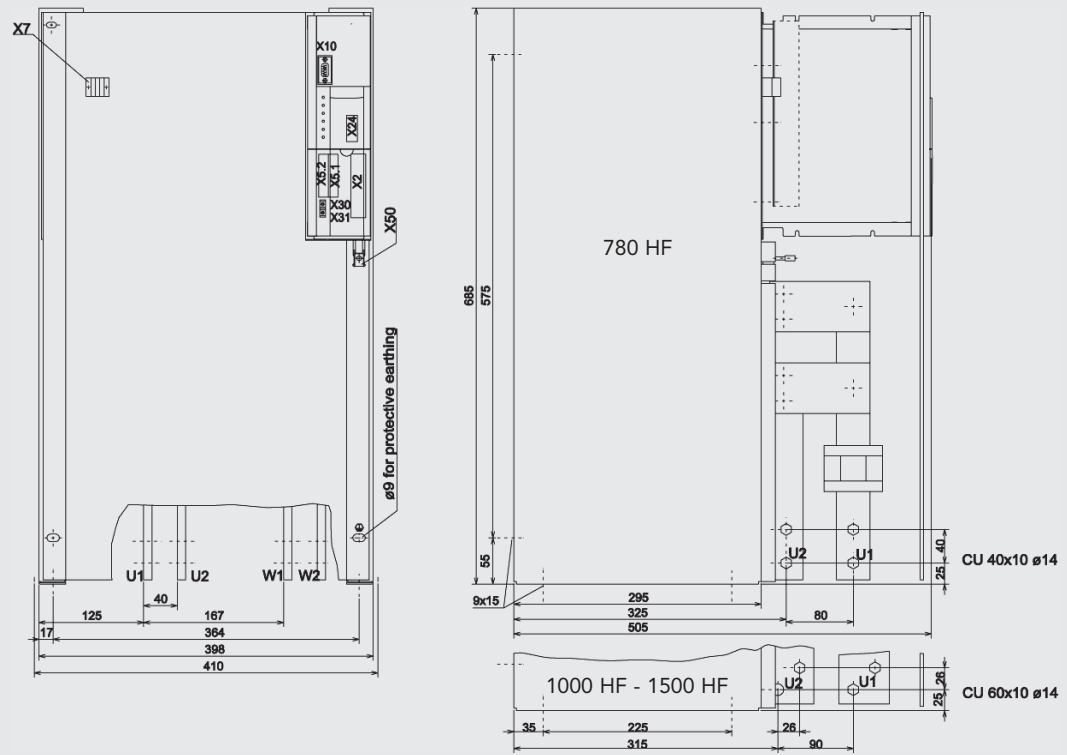

Thyro-P 2P (780 HF, 1000 HF, 1400 HF, 1500 HF)

Dimensional Drawing 280

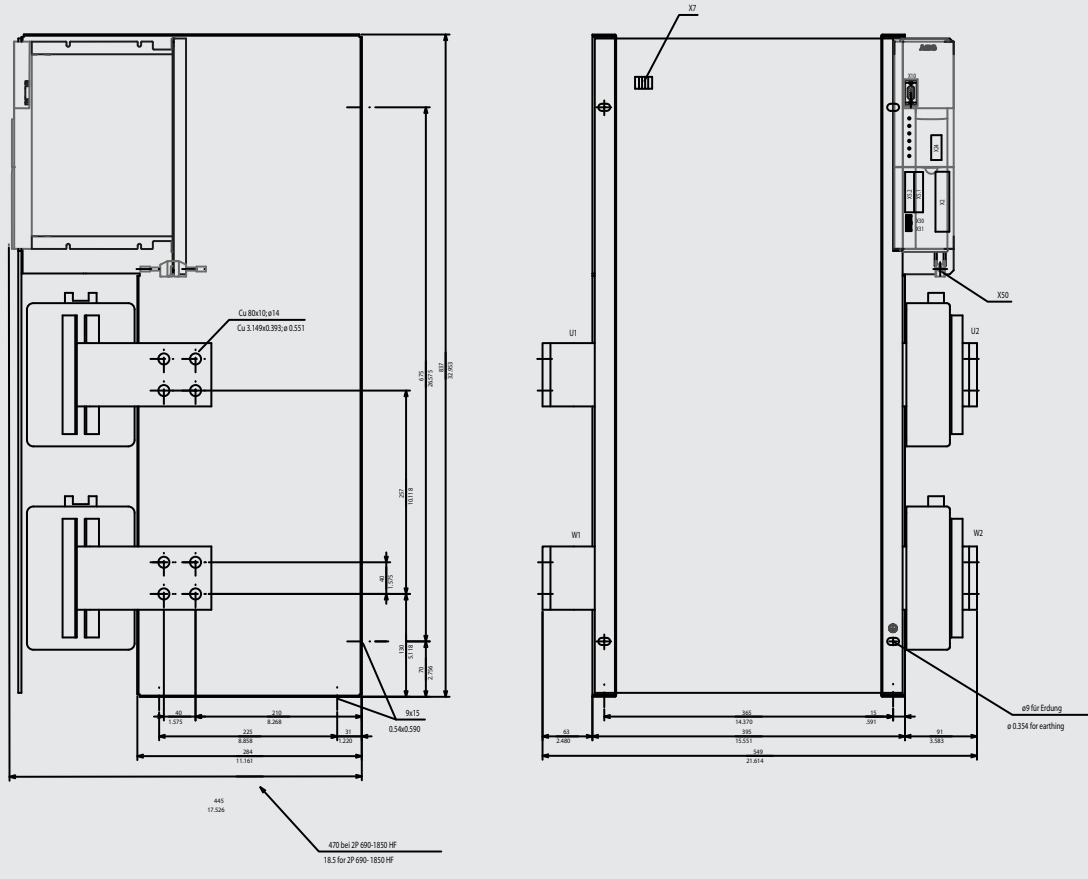

Thyro-P 2P (1850 HF, 2000 HF)

Dimensional Drawing 282

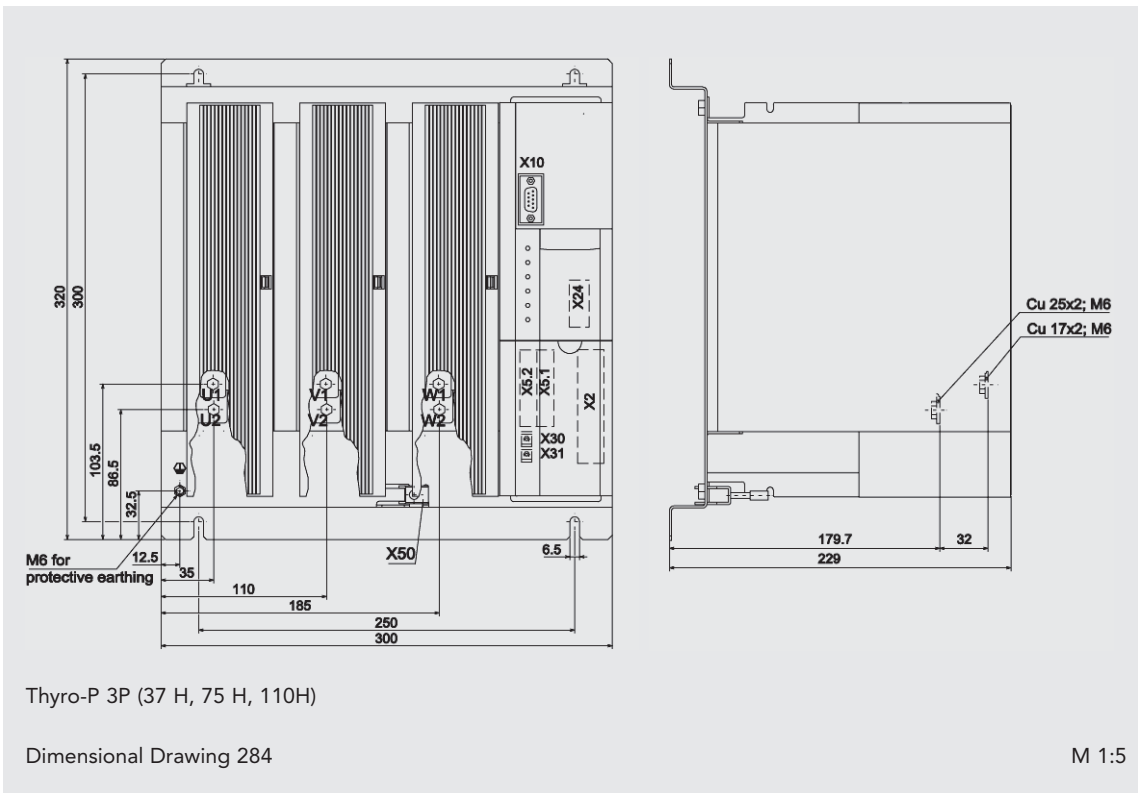
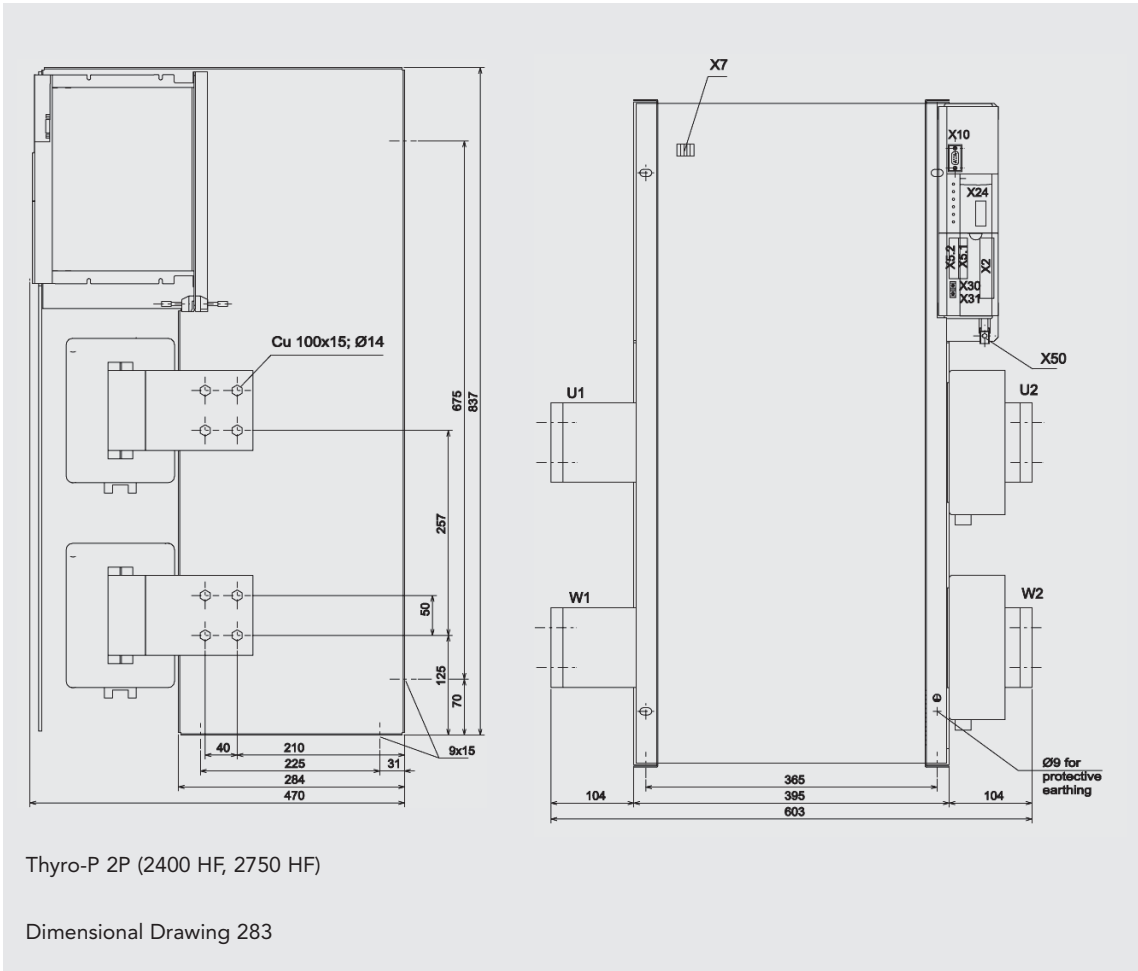

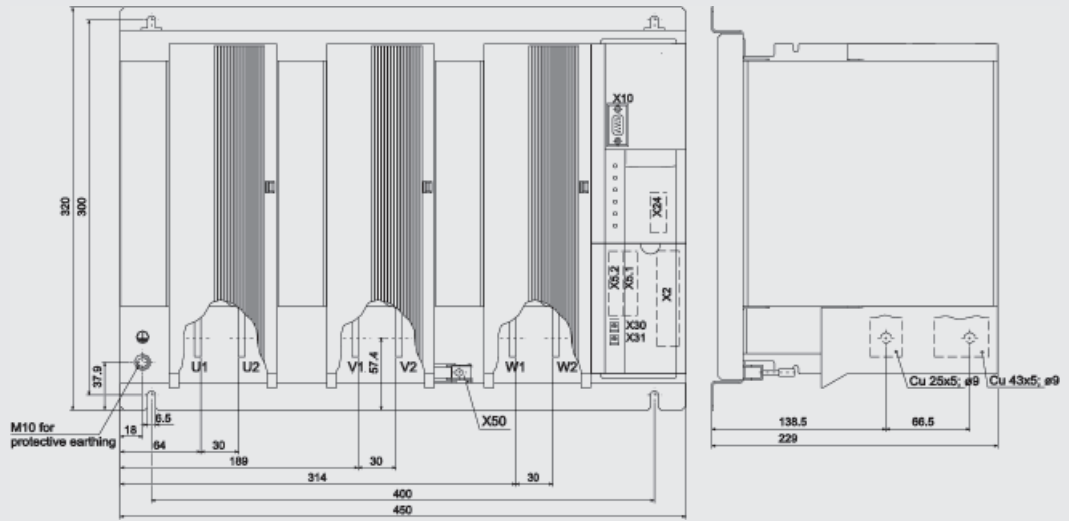

Thyro-P 3P (80 H, 130 H, 170 H)

Dimensional Drawing 287

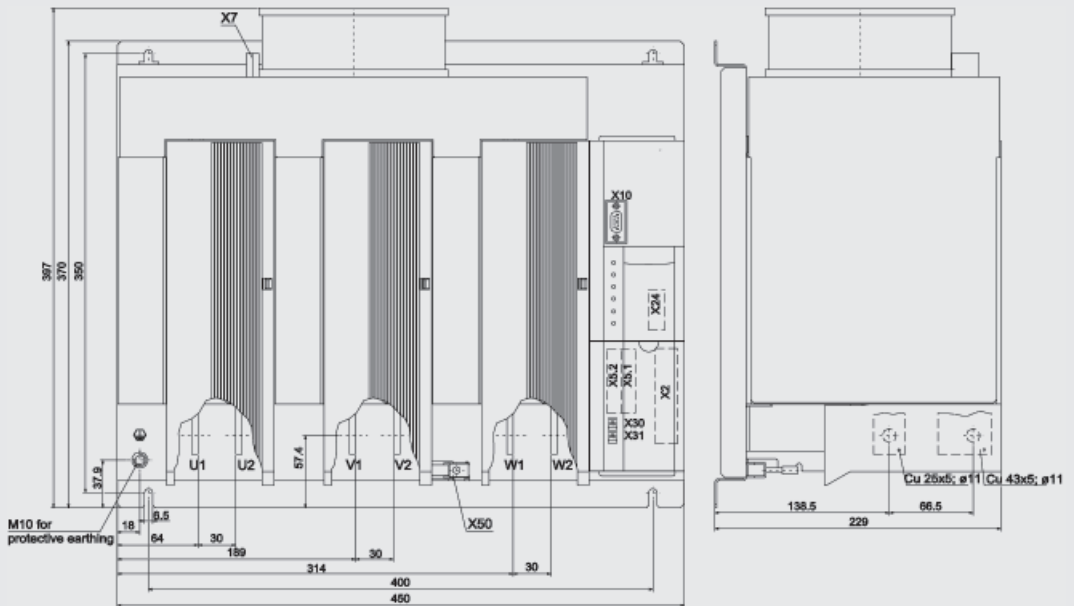

Thyro-P 3P (200 HF, 280 HF)

Dimensional Drawing 289

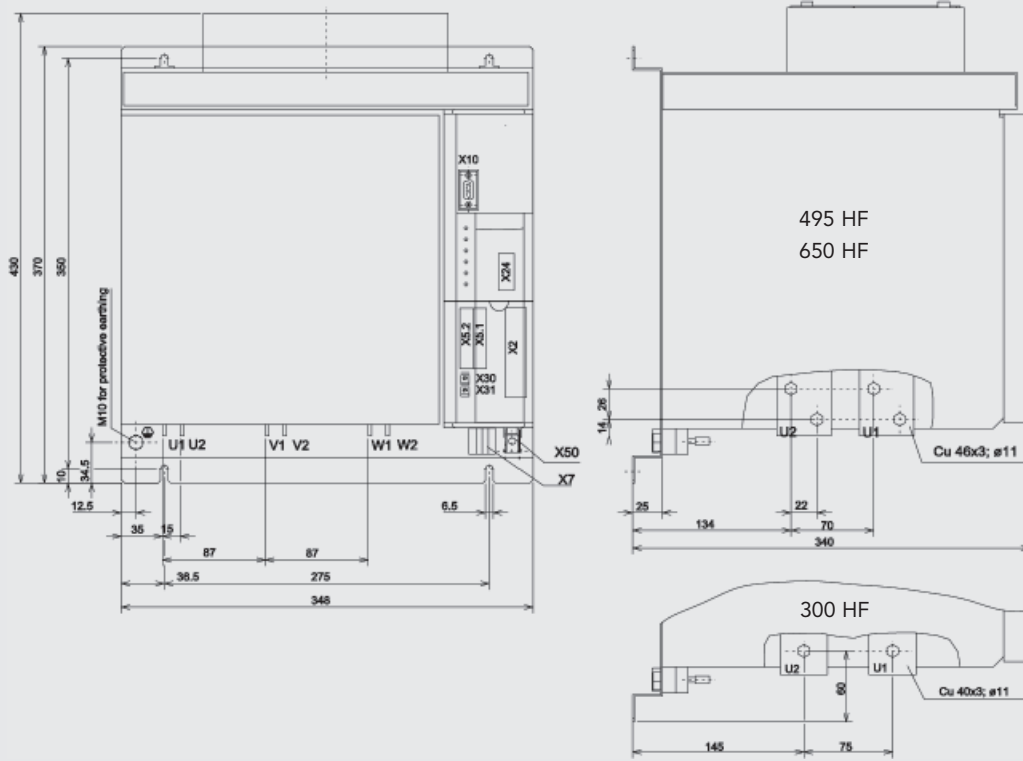

Thyro-P 3P (300 HF, 495 HF, 500 HF, 650 HF)

Dimensional Drawing 290

M 1:6

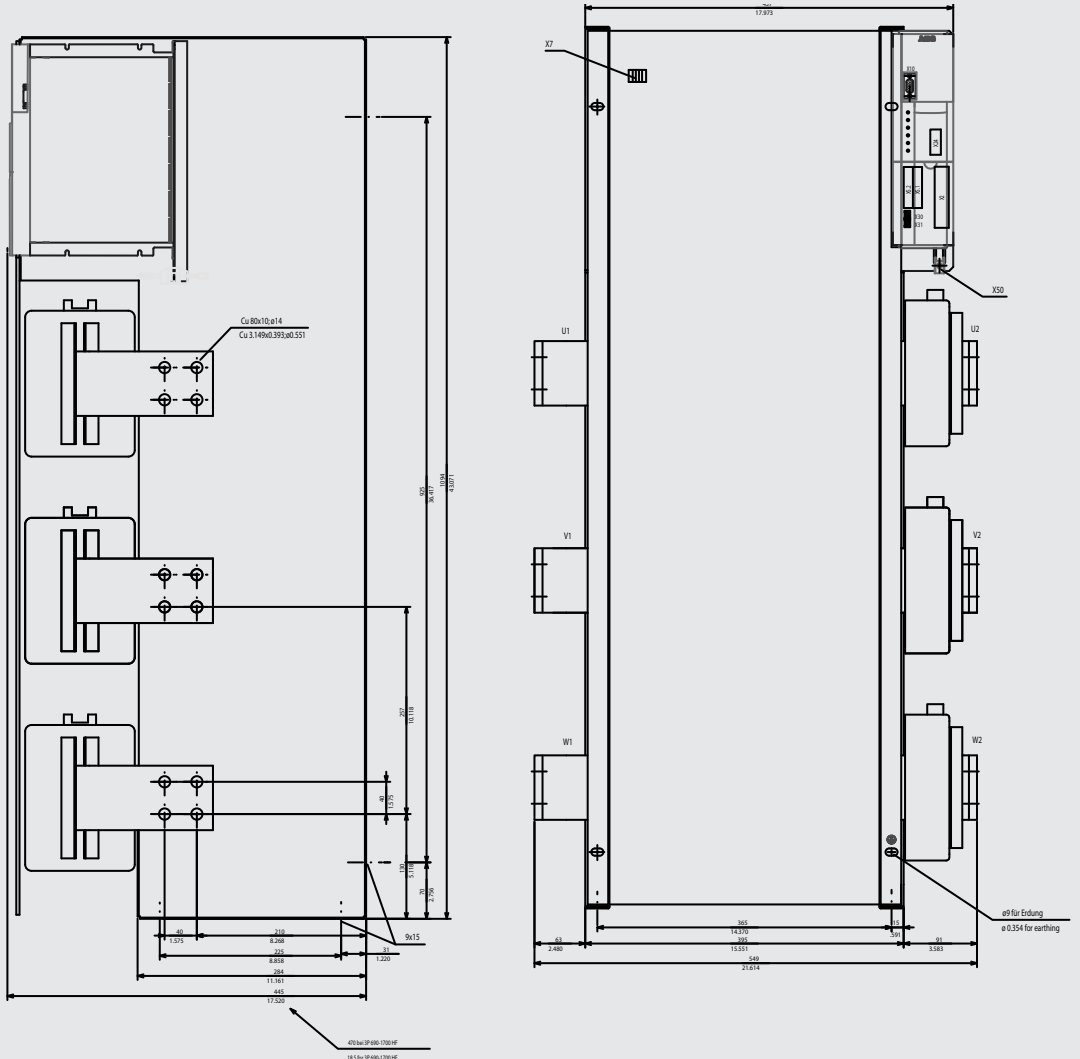

Thyro-P 3P (1700 HF, 1850 HF)

Dimensional Drawing 294

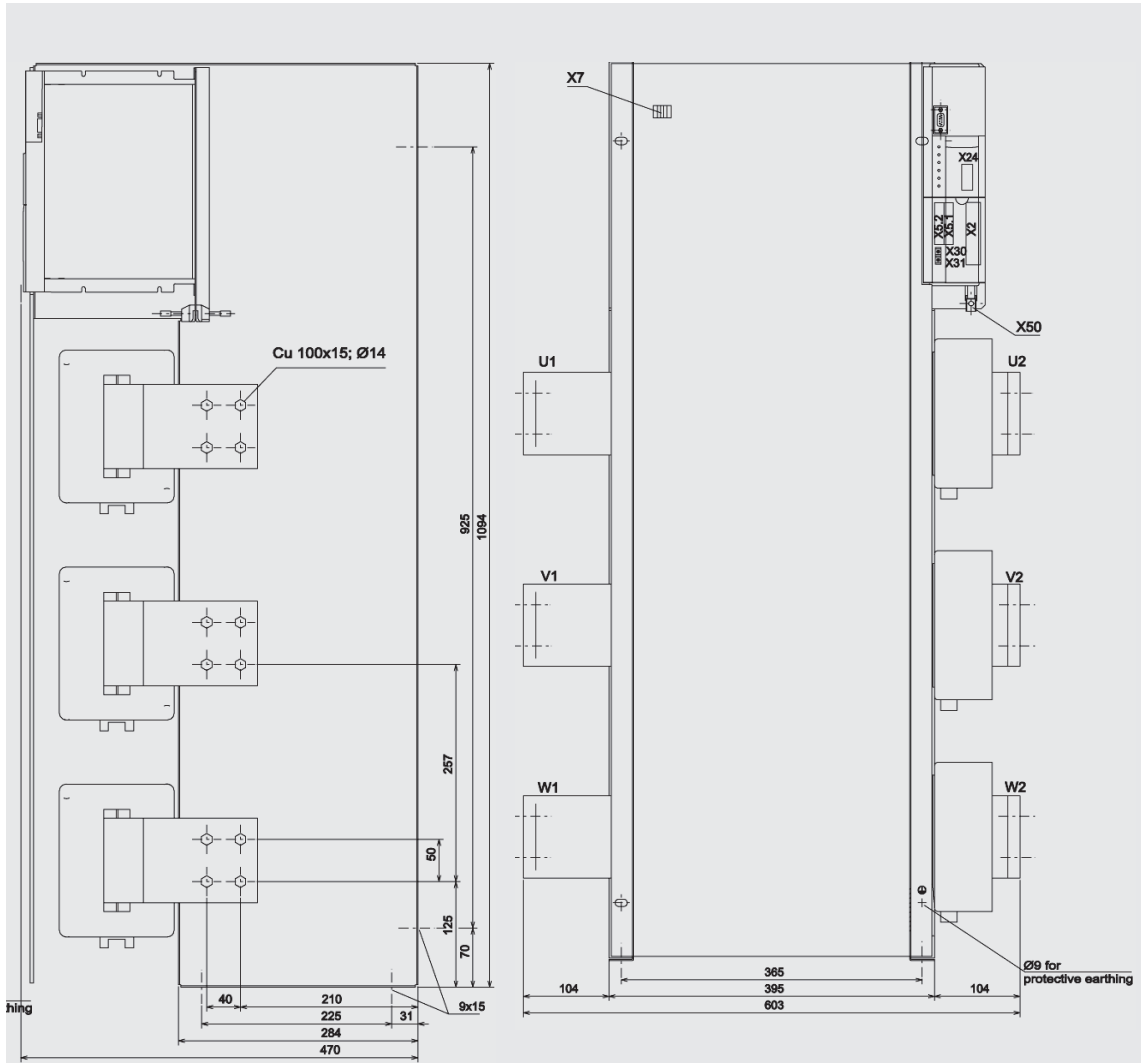

Thyro-P 3P (2200 HF, 2600 HF)

Dimensional Drawing 295

M 1:9

12. ACCESSORIES AND OPTIONS

ORDER NO.	DESCRIPTION
2000000380	Thyro-Tool Family, commissioning and visualization tool for simple visualization tasks; software under Windows 95/NT4.0 and later
2000000393	Thyro-P interface card Profibus-DP
2000000392	Thyro-P interface card Modbus RTU
2000000394	Thyro-P interface card DeviceNet
2000000400	control device for Thyro-1P, -2P and -3P
2000000401	control device as above, but using the ASM process for dynamic mains load optimization
2000000406	LBA, local operating and display unit, menu-driven, including copy function
2000000405	SEK, cabinet installation kit for LBA installation in switching cabinet door
2000000399	Voltage transformer 690V/43V (UE_U=016), for mounting on standard rails
37259800	LLV.V, fibre optic distribution power supply
37259900	LLV.4, fibre optic distribution
37295190	LL/RS 232 plug, (interface 9-pin) including power supply
0017381	fibre optic plug
0017574	fibre optic cable
8000007874	plug 2 pin for A70, X1
0048764	data cable to the PC (RS 232)
2000003203	Damping card 690V



13. APPROVALS AND CONFORMITIES

Due to European harmonization and international reconciliation, the standards will be subject to years of adjustment and renumbering. The detailed schedule therefore contains the current standards as well, even if the date for their expiry has already been set. There is no product norm for Thyristor Power Controllers, so that a sensible norm structure must be created from the corresponding basic norms, which ensures safe application and opportunity for comparison.



CAUTION

Thyristor Power Controllers are non-valid devices for disconnection and may therefore be operated only in connection with a suitable mains isolating device (for instance switch) connected on line side. Approvals and conformities are available for Thyro-P:

- Quality standard according to ISO 9001
- Registration in acc. to UL 508, file no. E 135074  
- Investigated under consideration to Canadian National Standard C22.2 No. 14-95
- UL Markings:
 - Field wiring terminal markings (see Chapter 4. „External Connections“)
 - Use 60/75°C Copper Conductors only
 - Tightening torque (pound inches) see Chapter 10. „Technical data“
 - Devices are suitable for the following short circuit current ratings:
 - Devices rated 300A
 - „Suitable For Use On A Circuit Capable Of Delivering Not More Than 100kA rms Symmetrical Amperes, xxx Volts Maximum, When Protected by RK5 Class Fuses, sized max. 600A / 600V“
 - Devices rated 495A and 695A:
 - „Suitable For Use On A Circuit Capable Of Delivering Not More Than 100kA rms Symmetrical Amperes, xxx Volts Maximum“

NOTE:

xxx = max. allowable voltage depending upon rating of the device

- „Branch circuit protection must be provided and sized according National Electrical Code and any additional local codes“
- CE conformity
 - Low Voltage Directive 73/23 EEC;
 - EMV Directive 89/336 EEC;
 - Marking Directive 93/68 EEC
- Interference suppression
 - The RegTP confirms the compliance with the interference suppression regulations for the power control device

IN DETAIL:

CONDITIONS FOR USE OF THE DEVICE

Built-in unit		EN 50 178
General requirements		EN 60146-1-1
Design, vertical installation		
Operating conditions		EN 60 146-1-1; K. 2.5
Operating location, industry sector		CISPR 6
Temperature performance		EN 60 146-1-1; K 2.2
Storage temperature		-25°C - +55°C
Transport temperature		-25°C - +70°C
Operating temperature		-10°C - +35°C for external cooling (280A) -10°C - +45°C for self air cooling -10°C - +55°C for reduced type current -2%/°C with UL applications up to 40°C
Load class	1	EN 60 146-1-1 T.2
Humidity class	B	EN 50 178 Tab. 7
Overvoltage voltage category ÜIII		EN 50 178 Tab. 3
Degree of pollution	2	EN 50 178 Tab. 2
Air pressure		900mbar \leq 1000m above zero level
Safe isolation		
up to 500V mains voltage:		EN 50 178 chap. 3
Air and creeping distances according to DIN EN 50178		casing/mains potential \geq 5.3mm casing/control potential \geq 5.3mm mains voltage/control potential \geq 7.2mm and 10mm in the power section interface/control potential \geq 2.5mm mains voltage/interface \geq 7.2mm mains voltage among themselves \geq 5.5mm
Test voltage		EN 50 178 Tab 18
Tests according to		EN 60 146-1-1 4.
EMV noise emission		EN 61000-6-4
Moise suppression (control device)		
	class A	CISPR 11
EMV noise resistance		EN 61000-6-2
Compatibility level	class 3	EN 61000-2-4
ESD	\geq 8 kV	EN 61000-4-2
Electromagnetic fields	\geq 10V/m	EN 61000-4-3
Burst on mains lines	\geq 2kV	EN 61000-4-4
Burst on control lines	\geq 0.5kV	
Surge on mains lines	\geq 2kV	EN 61000-4-5
Surge on control lines	\geq 0.5kV	
Line-conducted		EN 61000-4-6

Further norms are observed, for instance voltage dips according to 61000-4-11 are ignored by the control device, or registered by triggering of monitoring. Generally, an automated start is made after the mains returns within tolerances.

Therefore, the conditions of the norm EN 61326 (controller standard) are also observed, even though this norm by its structure is not applicable to power electronics > 10 respectively > 25A.



OPERATING INSTRUCTION / BETRIEBSANLEITUNG BAL 8000003232,
DE - EN, 06/12 - V6

Due to our policy of continuous development, the data in this document is subject to change without notice.
AEG is a registered trademark used under licence from AB Electrolux.

Aufgrund unserer kontinuierlichen Weiterentwicklung können die Daten in diesem Dokument ohne vorherige Ankündigung geändert werden.
AEG ist ein eingetragenes Warenzeichen verwendet unter Lizenz von AB Electrolux

AEG Power Solutions GmbH
Emil-Siepmann-Str. 32
59581 Warstein-Belecke - Germany
Tel.: +49 (0) 2902 763-520/-290 - Fax: +49 (0) 2902 763-1201
www.aegpowercontrollers.com - www.aegps.com

AEG
POWER SOLUTIONS